

TOSHIBA

SERVICE MANUAL

FILE NO. SVM-08012-2

AIR CONDITIONER

SPLIT WALL TYPE

RAS-13SKPX-IN-1 / RAS-13SAPX-IN-1
RAS-13SKP-E / RAS-13S2A-E

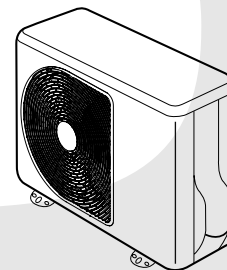
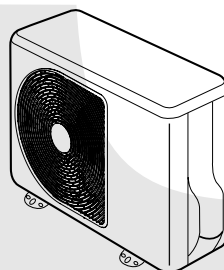
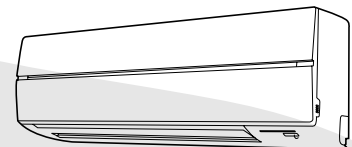

RAS-13SKPX-IN-1 / RAS-13SAPX-IN-1

RAS-13SKP-E / RAS-13S2A-E

Revised on June, 2008

CONTENTS

- 1. SPECIFICATIONS**
- 2. CONSTRUCTION VIEWS**
 - 2-1 Indoor Unit (RAS-13SKPX-IN-1)
 - 2-2 Indoor Unit (RAS-13SKP-E)
 - 2-3 Outdoor Unit
- 3. WIRING DIAGRAM**
 - 3-1 RAS-13SKPX-IN-1 / RAS-13SAPX-IN-1
 - 3-2 RAS-13SKP-E / RAS-13S2A-E
- 4. SPECIFICATION OF ELECTRICAL PARTS**
 - 4-1 Indoor Unit
 - 4-2 Outdoor Unit (RAS-13SAPX-IN-1)
 - 4-3 Outdoor Unit (RAS-13S2A-E)
- 5. REFRIGERATION CYCLE DIAGRAM**
 - 5-1 RAS-13SKPX-IN-1 / RAS-13SAPX-IN-1
 - 5-2 RAS-13SKP-E / RAS-13S2A-E
- 6. CONTROL BLOCK DIAGRAM**
- 7. OPERATION DESCRIPTION**
 - 7-1 Remote control
 - 7-2 Outline of Air Conditioner Control
 - 7-3 Description of Operation Mode
 - 7-4 Description of Safety and Reliability Prevention Function
 - 7-5 One-Touch Operation
 - 7-6 Hi POWER Operation
 - 7-7 QUIET Operation
 - 7-8 ECO Operation
 - 7-9 COMFORT SLEEP Operation
 - 7-10 FILTER Check lamp
 - 7-11 Auto Restart Function
 - 7-12 Self-Cleaning Operation

8. INSTALLATION PROCEDURE

- 8-1 Safety Cautions
- 8-2 Installation Diagram of Indoor and Outdoor Units
- 8-3 Installation
- 8-4 Indoor Unit
- 8-5 Outdoor Unit
- 8-6 How to Set Remote Control Selector Switch
- 8-7 Others

9. TROUBLESHOOTING CHART

- 9-1 Troubleshooting Procedure
- 9-2 Basic Check Items
- 9-3 Primary Judgement
- 9-4 Self-Diagnosis by Remote Control (Check Code)
- 9-5 Troubleshooting Flowcharts
- 9-6 Troubleshooting for Remote Control (Including The Indoor P.C. Board)

10. PARTS REPLACE MAIN PARTS

- 10-1 Indoor Unit
- 10-2 Outdoor Unit

11. EXPLODED VIEWS AND PARTS LIST

- 11-1 Indoor Unit (E-Parts Assy) RAS-13SKPX-IN-1
- 11-2 Indoor Unit (E-Parts Assy) RAS-13SKP-E
- 11-3 Indoor Unit (RAS-13SKPX-IN-1)
- 11-4 Indoor Unit (RAS-13SKP-E)
- 11-5 Outdoor Unit (RAS-13SAPX-IN-1)
- 11-6 Outdoor Unit (RAS-13S2A-E)

1. SPECIFICATIONS

MODEL		RAS-13SKPX-IN-1 / RAS-13SAPX-IN-1		RAS-13SKP-E / RAS-13S2A-E	
		Cooling			
Capacity	kW	230 V		220 V	240 V
		3.80		3.70	3.75
Power source	Phase	1∅			
	V	230 V		220 V	240 V
	Hz	50			
Power consumption	kW	1.23		1220	1260
Power factor	%	97		98	96
Running current	Indoor	A	0.15		0.15
	Outdoor	A	5.65		5.40
Starting current	A	25		24	
Moisture removal	lit/h	2.0		2.0	
Noise	Indoor (H/M/L)	dB	42/36/32		41/35/31
	Outdoor	dB	50		47 48
Refrigerant	Name of refrigerant		R22		R22
	Rated amount		1.00		0.71
Refrigerant control		Capillary tube			
Interconnection pipe	Gas side size	mm	∅12.7		∅12.7
	Connection type		Flare connection		
	Liquid side size	mm	∅6.35		
	Connection type		Flare connection		
	Maximum length (One way)	m	15*1		15*1
	Maximum height difference	m	6		6
INDOOR UNIT		RAS-13SKPX-IN-1		RAS-13SKP-E	
Dimensions	Height	mm	275		
	Width	mm	790		
	Depth	mm	205		
Net weight	kg	9			
Evaporator type		Finned tube			
Indoor fan type		Cross flow fan			
Air volume	High fan	m³/h	600		600
	Medium fan	m³/h	470		470
	Low fan	m³/h	360		360
Fan motor output	W	20			
Air filter		Honeycomb woven filter with PP frame			
OUTDOOR UNIT		RAS-13SAPX-IN-1		RAS-13S2A-E	
Dimensions	Height	mm	550		
	Width	mm	780		
	Depth	mm	290		
Net weight	kg	38		34	
Condenser type		Finned tube			
Outdoor fan type		Propeller fan			
Airflow volume	m³/h	2160		2120	2200
Fan motor output	W	42		30	
Compressor	Model	PH225X2C-4FT		PH22SX2C-4FT	
	Output	1100		1100	
Safety device		Fuse, Overload relay			
Louver type		Automatic louver			
Usable outdoor temperature range		°C 21 ~ 43			

Note : 1

- Capacity is based on the following temperature conditions.

Temperature	Condition	JIS C9612
		Cooling
Indoor unit inlet air temperature	(DB)	27°C
	(WB)	19°C
Outdoor unit inlet air temperature	(DB)	35°C
	(WB)	24°C

Note : 2

*1 No need to charge extra refrigerant.

2. CONSTRUCTION VIEWS

2-1. Indoor Unit

RAS-13SKPX-IN-1

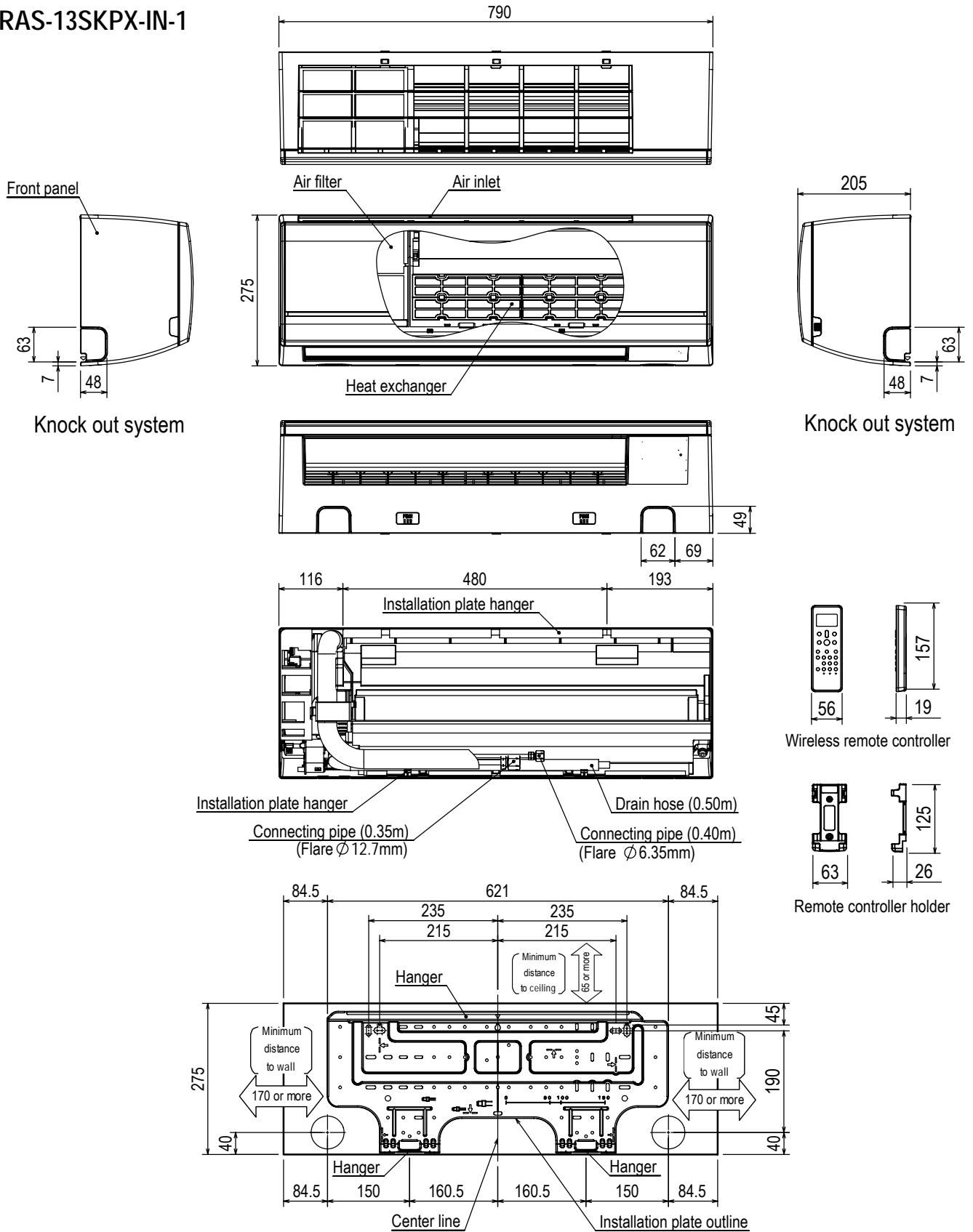

2-2. Indoor Unit

RAS-13SKP-E

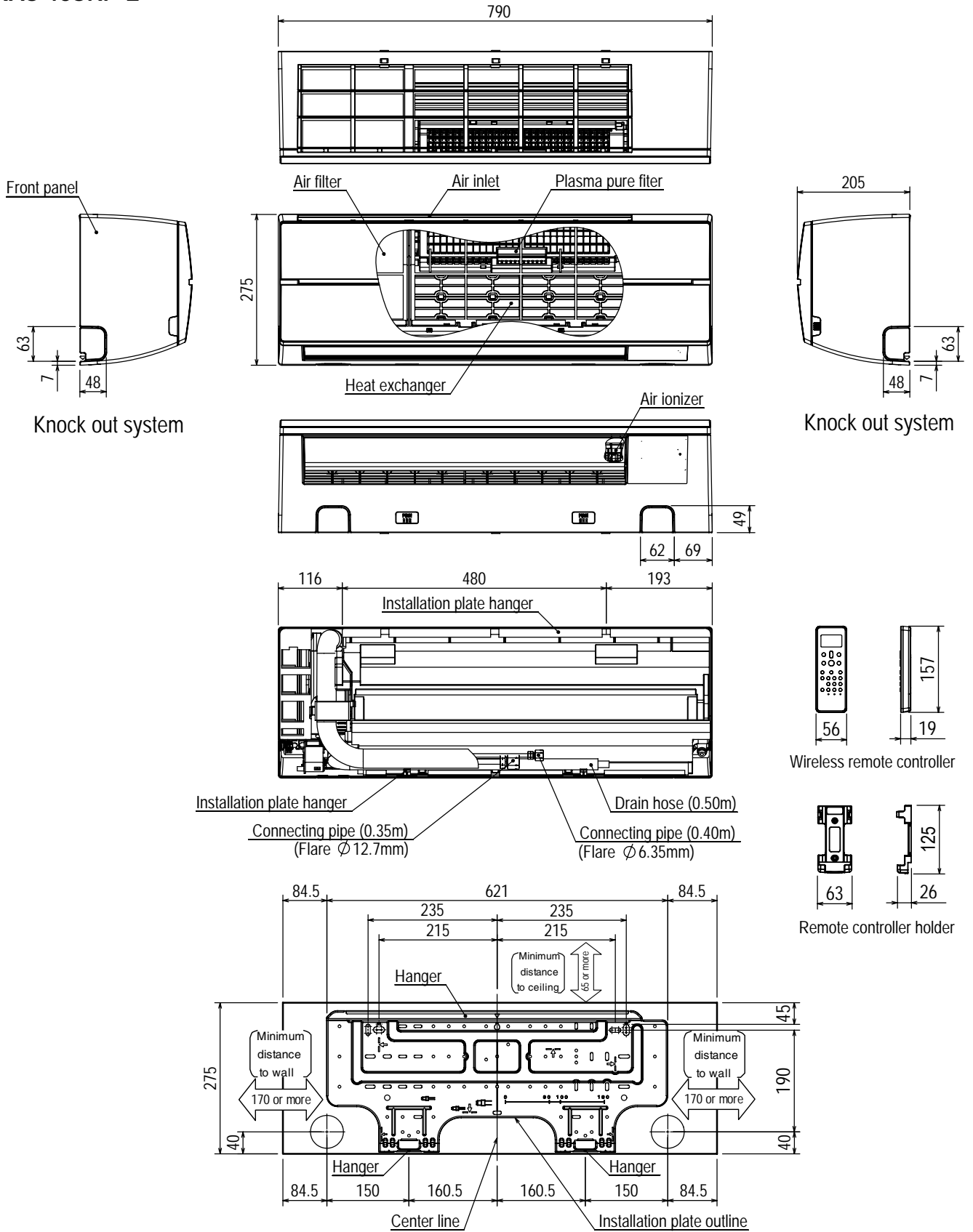

2-3. Outdoor Unit

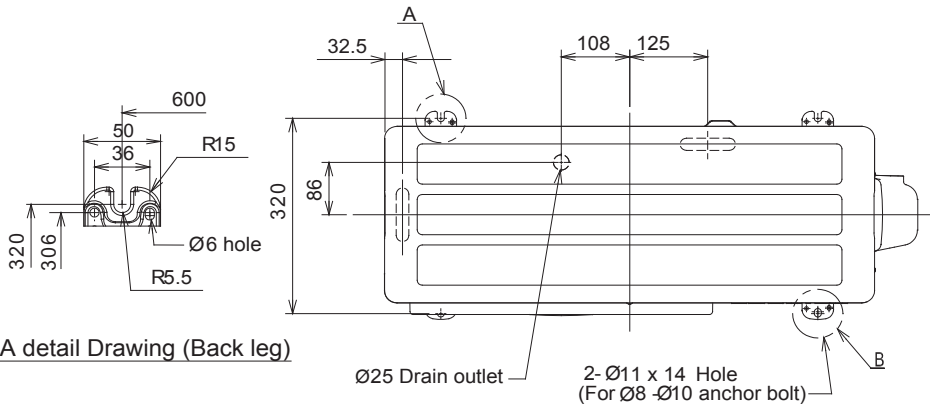

A detail Drawing (Back leg)

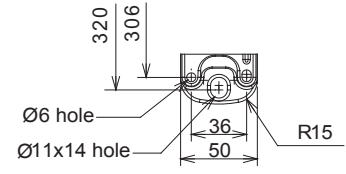

B Detail Drawing (Front leg)

Ø25 Drain outlet
2- Ø11 x 14 Hole
(For Ø8 -Ø10 anchor bolt)

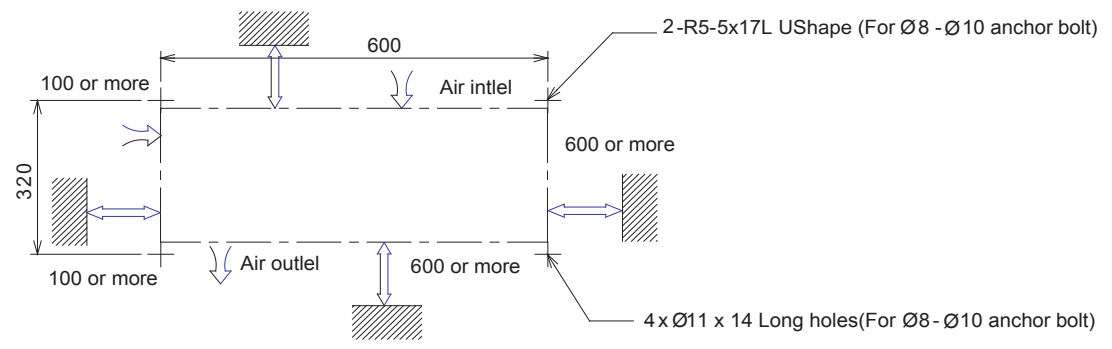
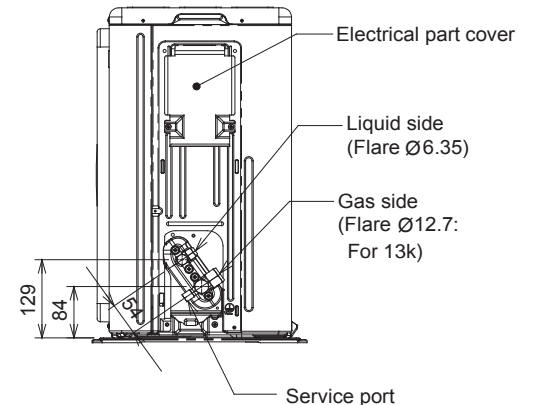
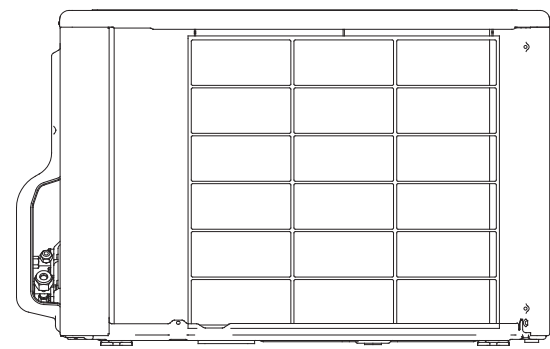
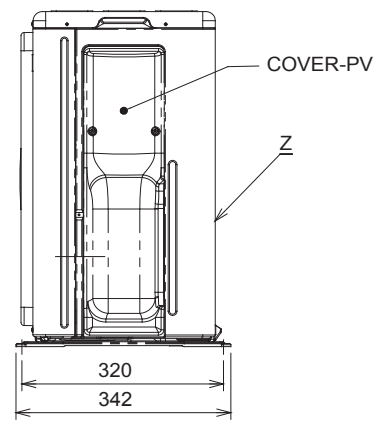
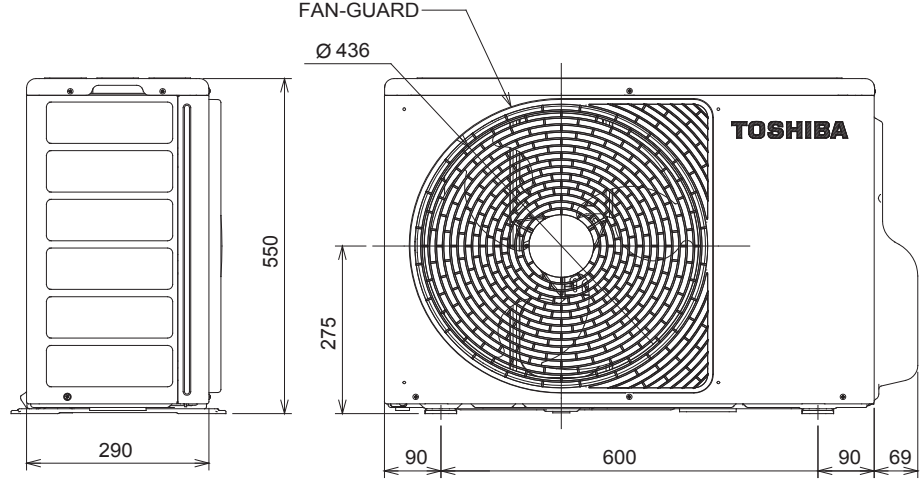

Installation dimension

3. WIRING DIAGRAM

3.1 RAS-13SKPX-IN-1 / RAS-13SAPX-IN-1

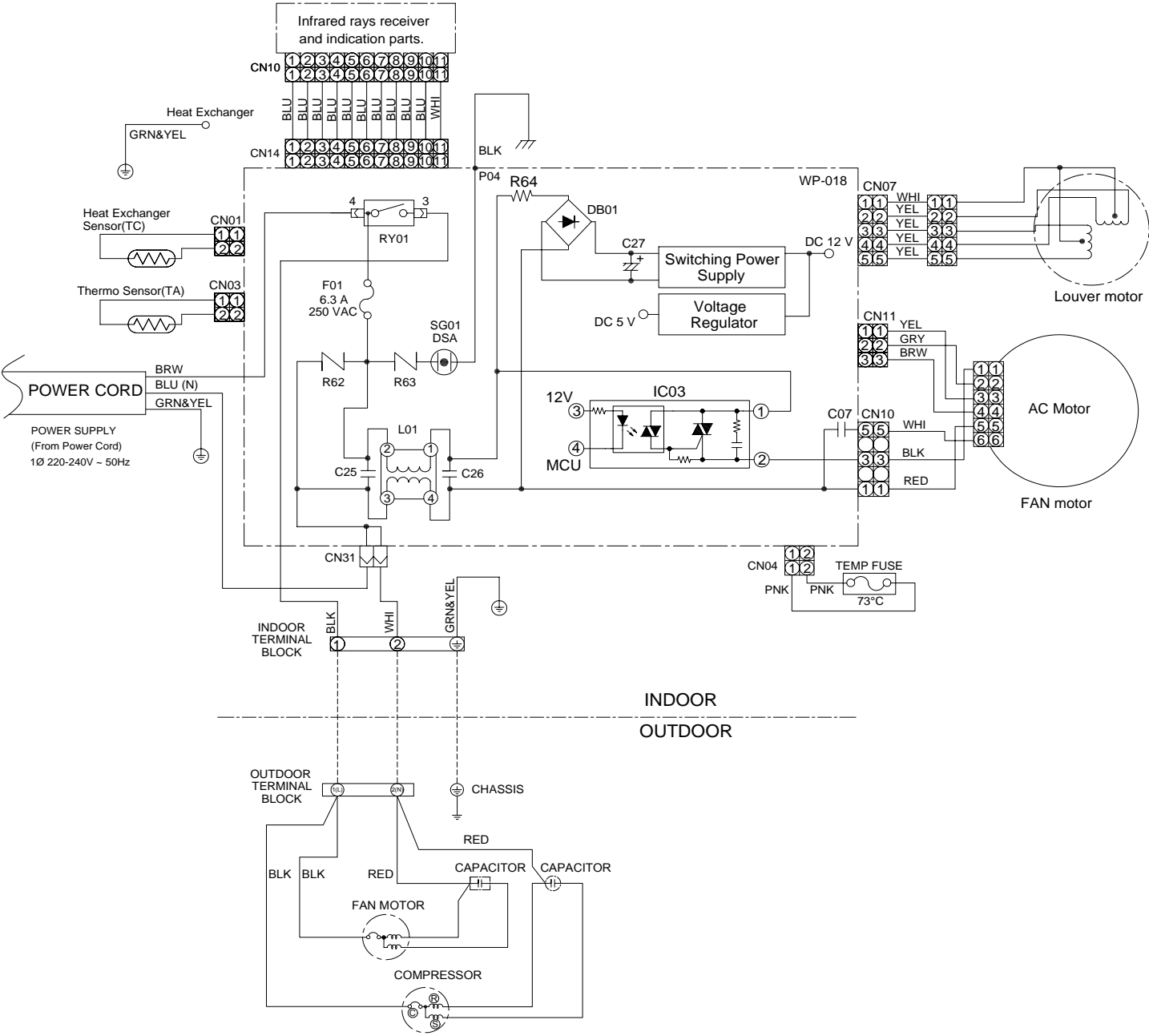

3. WIRING DIAGRAM

3.2 RAS-13SKP-E / RAS-13S2A-E

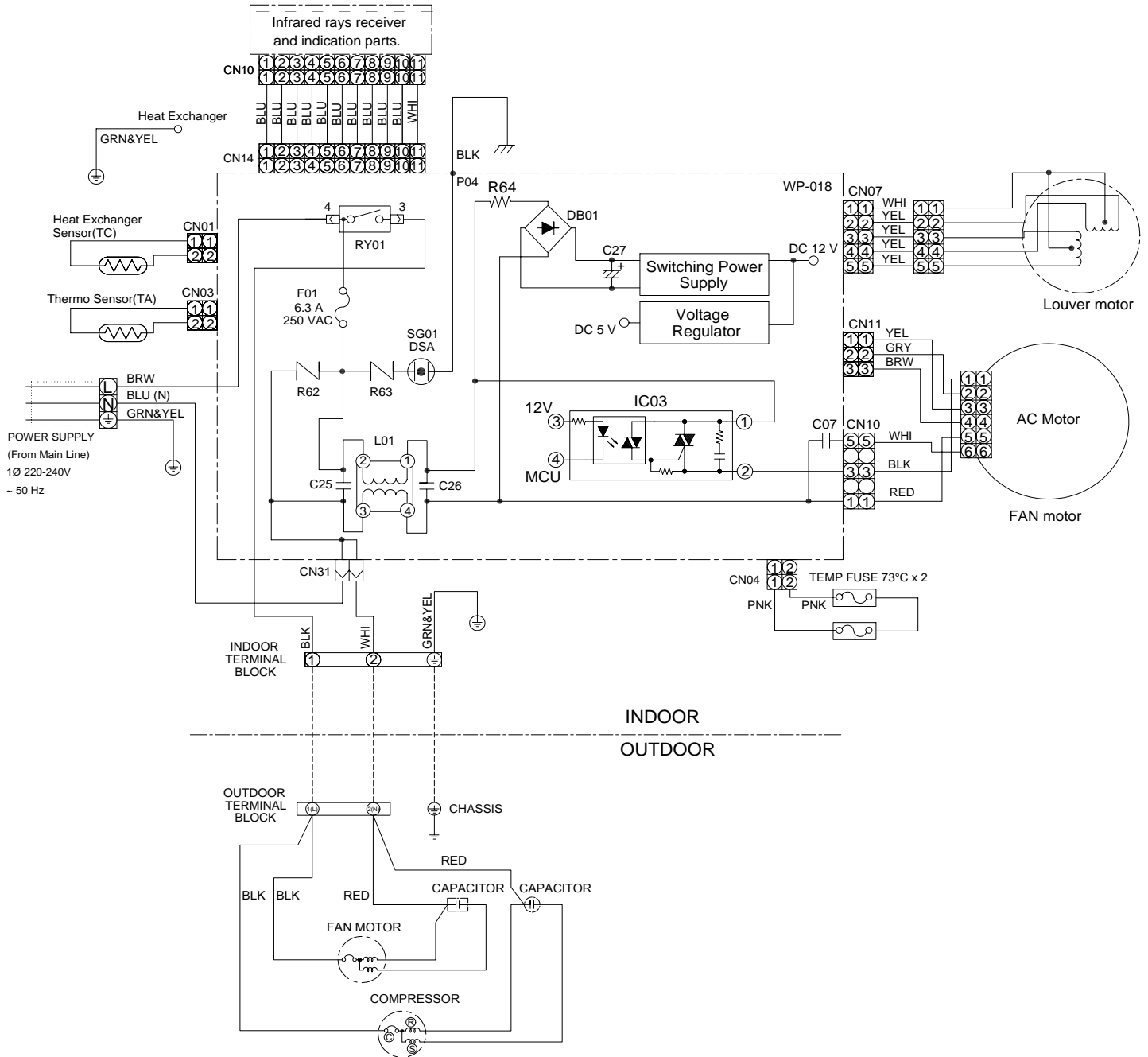

4. SPECIFICATION OF ELECTRICAL PARTS

4-1. Indoor Unit

No.	Parts name	Type	Specifications
1	Fan motor (for indoor)	AFS-220-20-4AR	AC Motor with 145°C thermo fuse
2	Thermo sensor (TA-sensor)		10kΩ at 25°C
3	Transformer	ST-001	
4	Microcontroller unit (IC30)	TMP87CM40ANG	
5	Heat exchanger sensor (TC-sensor)		10kΩ at 25°C
6	Line filter (L01)	SS11V-06270	27mH, 600mA
7	Bridge rectifier (DB01)	DB105G	1.5A, 600VA
8	Capacitor (C27)	EKMH401VSN470MP20S	47μF, 400V
9	Fuse (F01)	FJL250V6.3A	T6.3A, 250VAC
10	Varistor (R62, R63)	SR561K14DL	560V
11	Louver motor	MP24Z3T	12VDC
12	Relay (Comp., RY01)	G4A-1A	Rating 25A/AC250V

4-2. Outdoor Unit (RAS-13SAPX-IN-1)

No.	Parts name	Type	Specifications		
1	Compressor	PH225X2C-4FT	Output (Rated) 1100 W, 2 poles, 1 phase, 220 V~, 50Hz		
			Winding resistance (W) (at 20°C)	C-R	C-S
				2.35	3.22
2	Fan motor (for outdoor)	WLF-240-42A	Output (Rated) 42 W, 6 poles, 1 phase, 220 - 240 V~, 50/60Hz		
			Winding resistance (W) (at 20°C)	Red-Black	White-Black
				188	289
3	Running capacitor (for fan motor)	DS451155NPQB	AC 450 V~, 1.5μF		
4	Running capacitor (for compressor)	RS44B356U0215S	AC 440 V~, 35μF		

4-3. Outdoor Unit (RAS-13S2A-E)

No.	Parts name	Type	Specifications		
1	Compressor	PH225X2C-4FT	Output (Rated) 1100 W, 2 poles, 1 phase, 220V~, 50Hz		
			Winding resistance (Ω) (at 20°C)	C-R	C-S
				2.35	3.22
2	Fan motor (for outdoor)	WLF-240-30A	Output (Rated) 30 W, 6 poles, 1 phase, 220 -240V~, 50/60Hz		
			Winding resistance (Ω) (at 20°C)	Red-Black	White-Black
				237	380
3	Running capacitor (for fan motor)	DS451155NPQB	AC 450V~, 1.5 μ F		
4	Running capacitor (for compressor)	RS44B356U0215S	AC 440V~, 35 μ F		

5. REFRIGERATION CYCLE DIAGRAM

5-1. RAS-13SKPX-IN-1 / RAS-13SAPX-IN-1

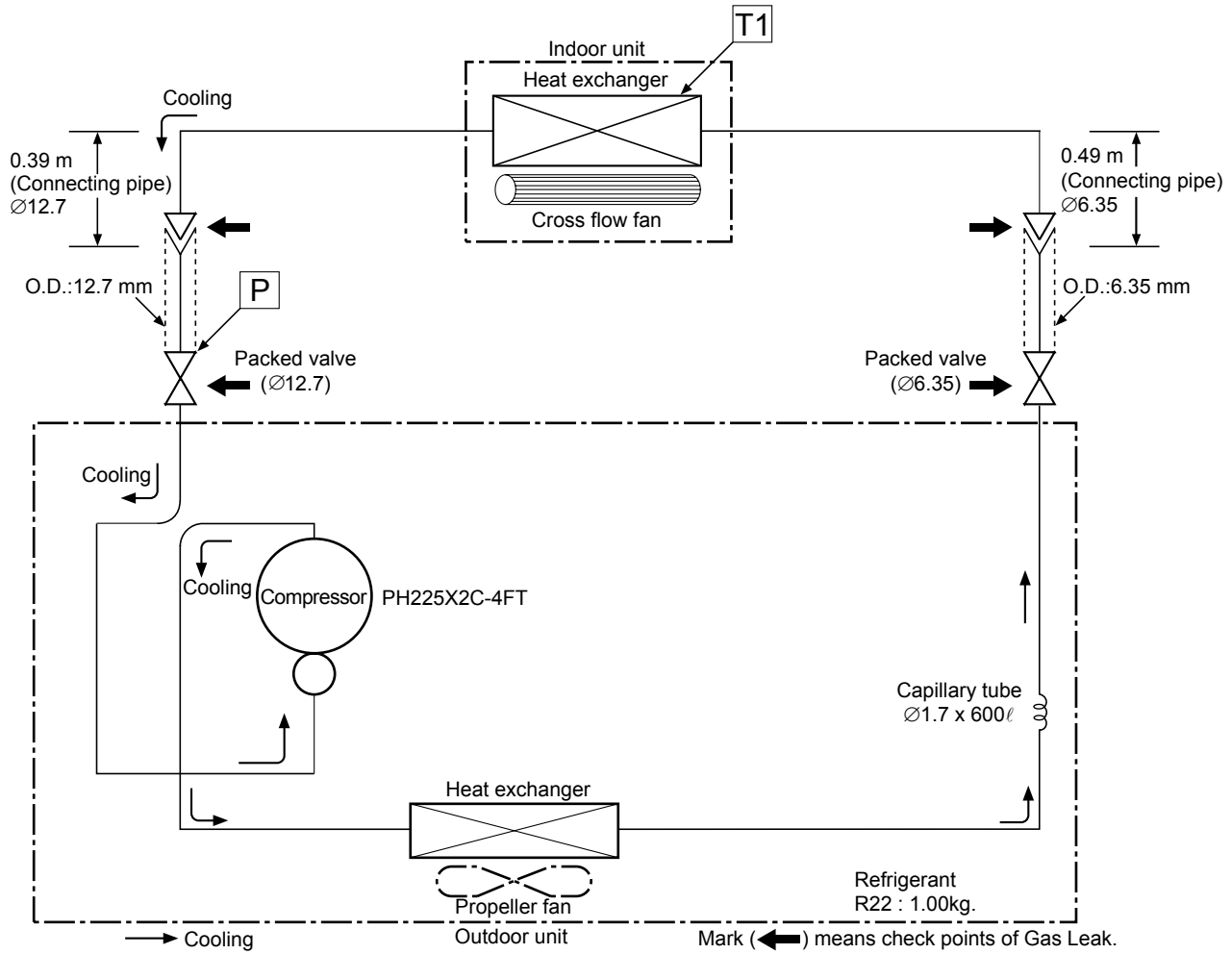

50Hz		Standard pressure P (MPaG)	Surface temp. of heat exchanger interchanging pipe T1 (°C)	Fan speed (indoor)	Ambient temp. conditions DB/WB (°C)	
					Indoor	Outdoor
Cooling	Standard	0.50	10.0	High	27/19	35/24
	Overload	0.58	15.0	High	32/23	43/26
	Low temperature	0.45	2.0	Low	21/15	21/15

Note

- Measure the heat exchanger temperature at the center of U-bend. (By means of TC sensor)

5-2. RAS-13SKP-E / RAS-13S2A-E

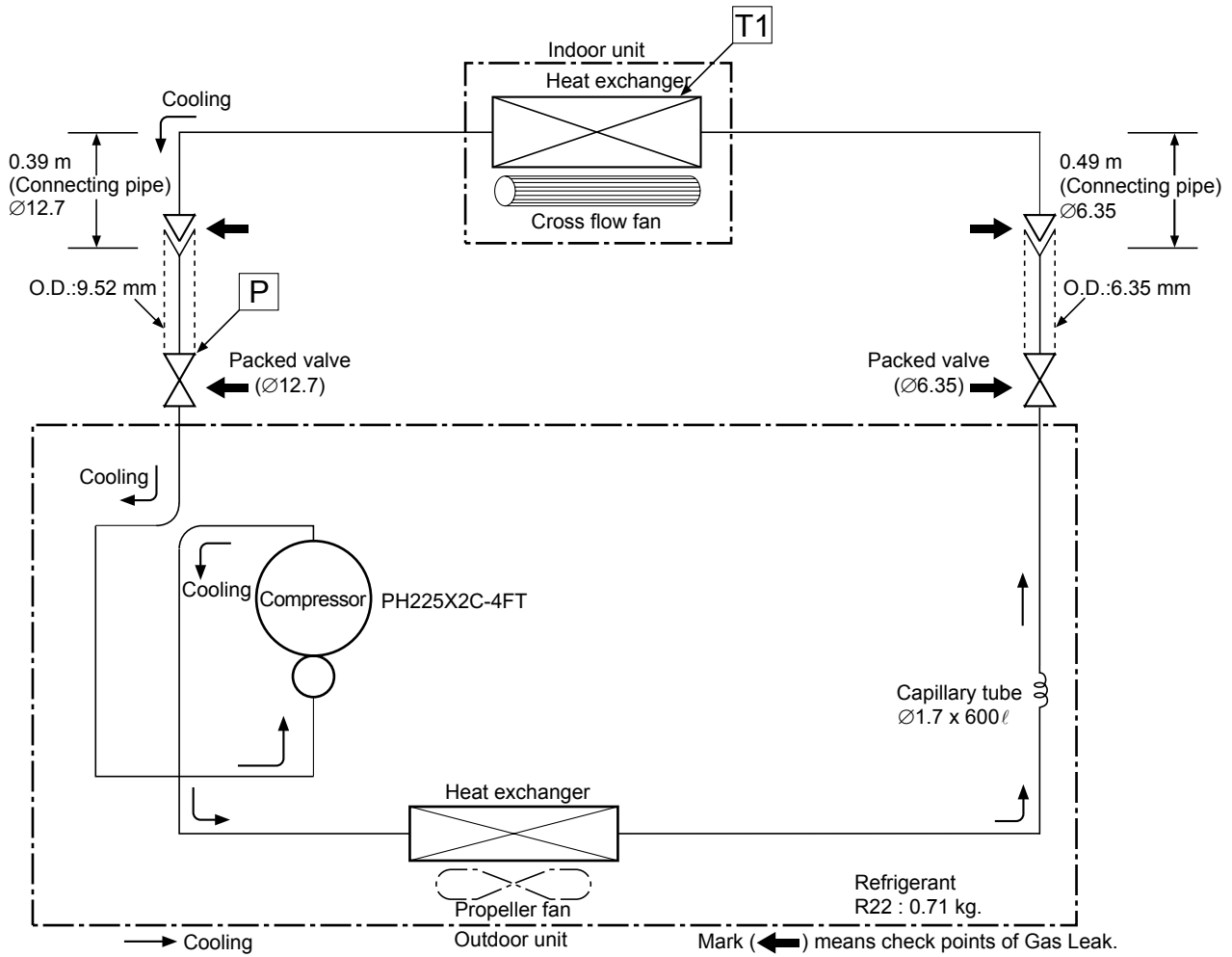

50Hz		Standard pressure P (MPaG)	Surface temp. of heat exchanger interchanging pipe T1 (°C)	Fan speed (indoor)	Ambient temp. conditions DB/WB (°C)	
					Indoor	Outdoor
Cooling	Standard	0.49	10.5	High	27/19	35/24
	Overload	0.58	15.0	High	32/23	43/26
	Low temperature	0.40	2.0	Low	21/15	21/15

Note

- Measure the heat exchanger temperature at the center of U-bend. (By means of TC sensor)

6. CONTROL BLOCK DIAGRAM

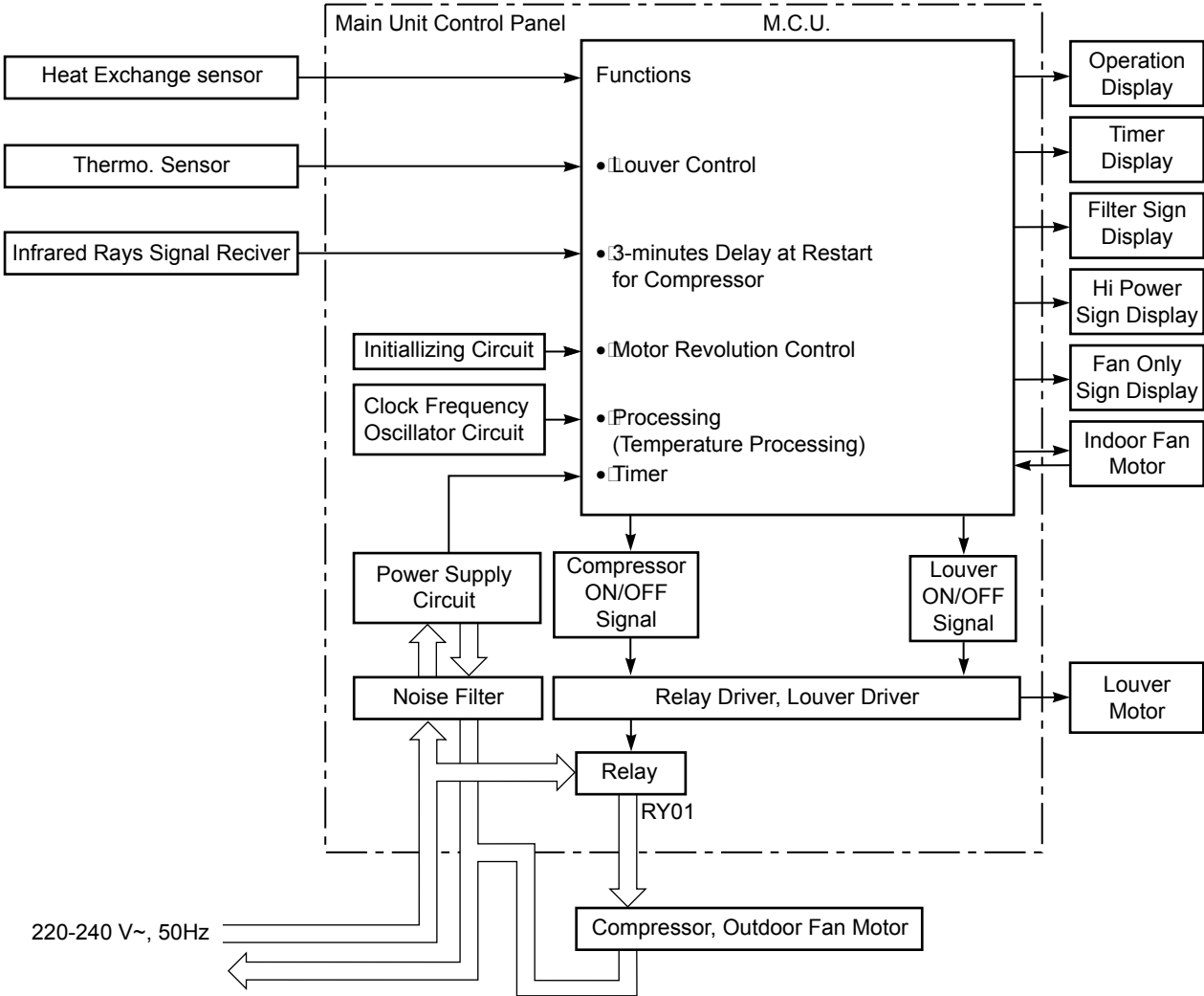

REMOTE CONTROL

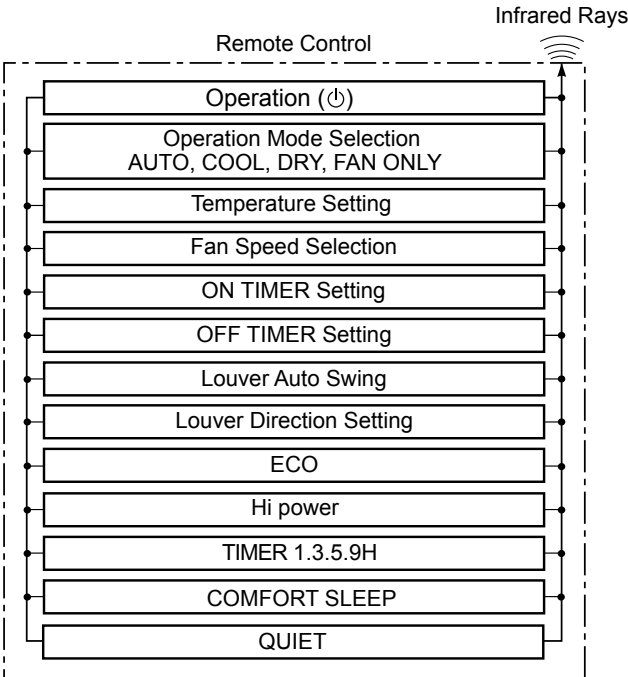

7. OPERATION DESCRIPTION

7-1. Remote control

7-1-1. Function of Push Button

- ① Infrared signal emitter
- ② Start/Stop button
- ③ Mode select button (MODE)
- ④ Temperature button (TEMP)
- ⑤ Fan speed button (FAN)
- ⑥ Swing louver button (SWING)
- ⑦ Set louver button (FIX)
- ⑧ On timer button (ON)
- ⑨ Off timer button (OFF)
- ⑩ Sleep timer button (SLEEP)
- ⑪ Timer setup button (SET)
- ⑫ Timer clear button (CLR)
- ⑬ Memory and Preset button (PRESET)
- ⑭ One Touch button (ONE-TOUCH)
- ⑮ High power button (Hi-POWER)
- ⑯ Economy button (ECO)
- ⑰ Quiet button (QUIET)
- ⑱ Comfort sleep button (COMFORT SLEEP)
- ⑲ Filter reset button (FILTER)
- ⑳ Clock Reset button (CLOCK)
- ㉑ Check button (CHK)

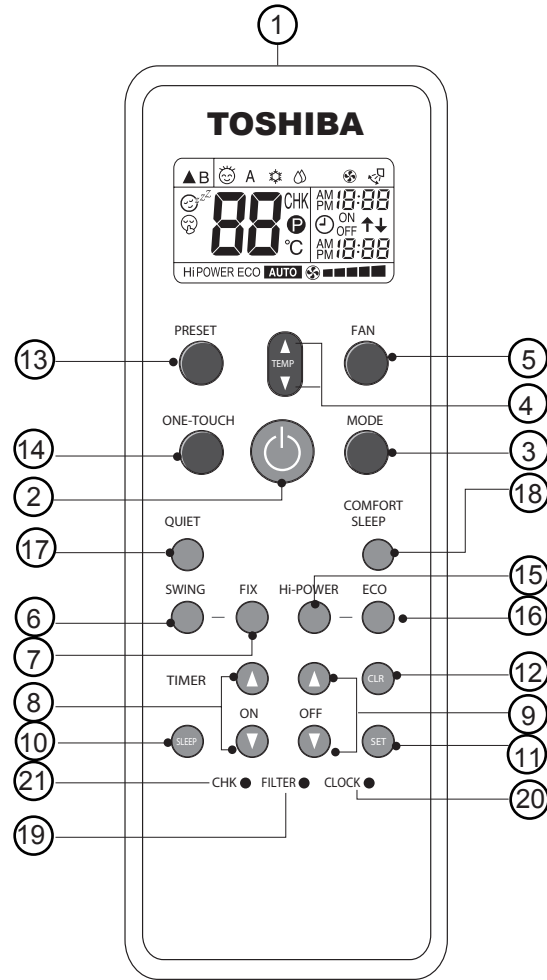



7-1-2. Display of Remote Control

All indications, except for the clock time indicator, are displayed by pressing the  button.

1. Transmission mark

This transmission mark  indicates when the remote controller transmits signals to the indoor unit.







2. Mode indicator

Indicates the current operation mode.
(A : Auto,  : Cool,  : Dry,  : Fan only)

3. Temperature indicator

Indicates the temperature setting.
(17°C to 30°C)

4. FAN speed indicator

Indicates the selected fan speed.
AUTO or five fan speed levels
(LOW  , LOW+  , MED  , MED+  , HIGH ) can be shown.
Indicates AUTO when the operating mode is either AUTO or  : Dry.

5. TIMER and clock time indicator

The time setting for timer operation or the clock time is indicated.
The current time is always indicated except during TIMER operation.

6. Hi-POWER indicator

Indicates when the Hi-POWER operation starts.
Press the Hi-POWER button to start and press it again to stop the operation.

7. (PRESET) indicator

Flashes for 3 seconds when the PRESET button is pressed during operation.
The  mark is shown when holding down the button for more than 3 seconds while the mark is blinks.
Press another button to turn off the mark.

8. ECO indicator

Indicates when the ECO is in activated.
Press the ECO button to start and press it again to stop operation.

9. A, B change indicator remote controller

When the remote controller switching function is set, "B" appears in the remote controller display.
(When the remote controller setting is "A", there is no indication at this position.)

10. Comfort sleep

Indicates when comfort sleep is activated.
Press comfort sleep button to selecter

11. Quiet

Indicates when quiet is activated.
Press quiet button to start and press it again to stop operation.

12. One-Touch

Indicates when one touch comfort is activated.
Press one-touch button to start the operation.

13. Swing

Indicates when louver is swing.
Press swing button to start the swing operation and press it again to stop the swing operation.

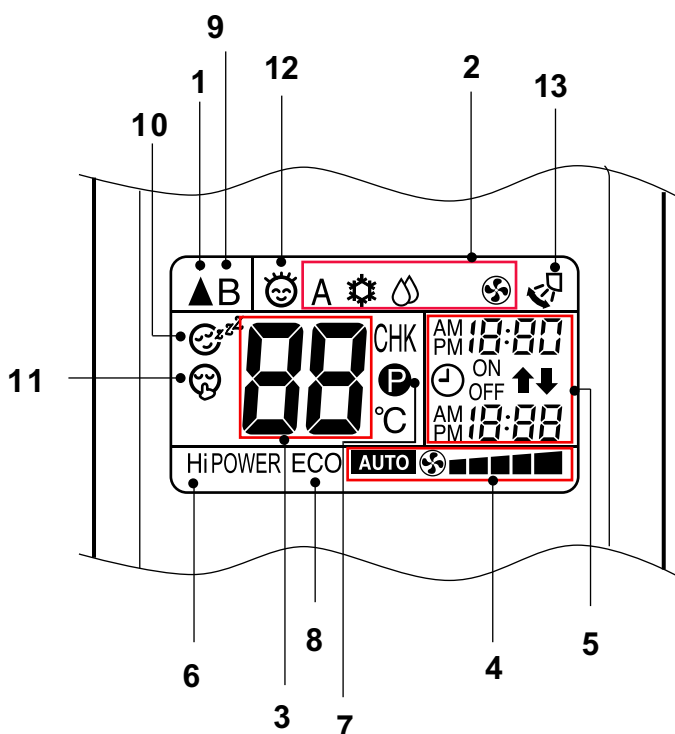

7-2. Outline of Air Conditioner Control

This is a fixed capacity type air conditioner, which uses a AC motor for an indoor fan. The AC motor drive circuit is mounted in the indoor unit. And electrical parts which operate the compressor and the outdoor fan motor, are mounted in the outdoor unit.

The air conditioner is mainly controlled by the indoor unit controller. The controller operates the indoor fan motor based upon commands transmitted by the remote control and transfers the operation commands to the outdoor unit.

The outdoor unit receives operation commands from the indoor unit, and operates the outdoor fan motor and the compressor.

(1) Role of indoor unit controller

The indoor unit controller receives the operation commands from the remote control and executes them.

- Temperature measurement at the air inlet of the indoor heat exchanger by the indoor temperature sensor
- Temperature measurement of the indoor heat exchanger by the heat exchanger sensor
- Louver motor control
- Indoor fan motor operation control
- LED display control
- Transferring of operation commands to the outdoor unit
- Receiving of information of the operation status and judging of the information or indication of error

(2) Role of outdoor unit controller

The outdoor unit controller receives the operation commands from the indoor controller and executes them.

- Compressor operation control
 - Operation control of outdoor fan motor
- } Operations according to the commands from the indoor unit
- Turning off the compressor and outdoor fan when the outdoor unit receives the shutdown command

7-2-1. Louver control

(1) Vertical air flow louver

Position of vertical air flow louver is automatically controlled according to the operation mode.

Besides, position of vertical air flow louver can be arbitrarily set by pressing [FIX] button.

The louver position which is set by [FIX] button is stored in the microcomputer, and the louver is automatically set at the stored position for the next operation.

(2) Swing





If [SWING] button is pressed when the indoor unit is in operation, the vertical air flow louver starts swinging. When [SWING] button is pressed, it stops swinging.

7-2-2. Indoor Fan Control

The operation controls the fan speed at indoor unit side. The indoor fan (cross flow fan) is operated by the phase control induction motor. The fan rotates in 5 stages in MANUAL mode, and in 5 stages in AUTO mode, respectively. (Table 7-2-2)

- 1) When setting the fan speed to L, L+, M, M+ or H on the remote controller, the operation is performed with the constant speed shown in Table 7-2-1

Table (7-2-1)

Indication	Fan speed
L 	Low
L+ 	(L + M) / 2
M 	Med
M+ 	(M + H) / 2
H 	High

- 2) When setting the fan speed to AUTO on the remote controller, revolution of the fan motor is controlled to the fan speed level shown in Table 7-2-2 according to the setup temperature, room temperature, and heat exchanger temperature.

Table 7-2-2 Indoor fan and air flow rate

OPERATION MODE		FAN TAP													
		Cooling	UH	H	M+	M	L+	L	L-	UL	SL				
		Fan only		H	M+	M	L+	L	L-						
		Dry			M+	M	L+	L	L-	UL	SL				
Model	RAS-13SKPX-IN-1	Fan speed (rpm)	1300	1250	1160	1100	1060	1000	970	880	800	750	700	650	600
	RAS-13SKP-E	Air flow volume (m ³ /h)	620	600	530	490	470	430	420	360	320	290	260	230	200

7-3. Description of Operation Mode

- (1) When turning on the breaker, the operation lamp blinks. This means that the power is on (or the power supply is cut off.)
- (2) When pressing [⏻] button on the remote control, receiving beep sounds from the indoor unit, and the next operation is performed together with opening the vertical air flow louver.
- (3) Once the operation mode is set, it is memorized in the microcomputer so that the previous operation can be effected thereafter simply by pressing [⏻] button.

7-3-1. Fan only operation

([MODE] button on the remote control is set to the fan only operation.)

- (1) When [FAN] button is set to AUTO, the indoor fan motor operates as shown in Fig. 7-3-1. When [FAN] button is set to LOW, LOW⁺, MED, MED⁺ or HIGH, the motor operates with a constant air flow.

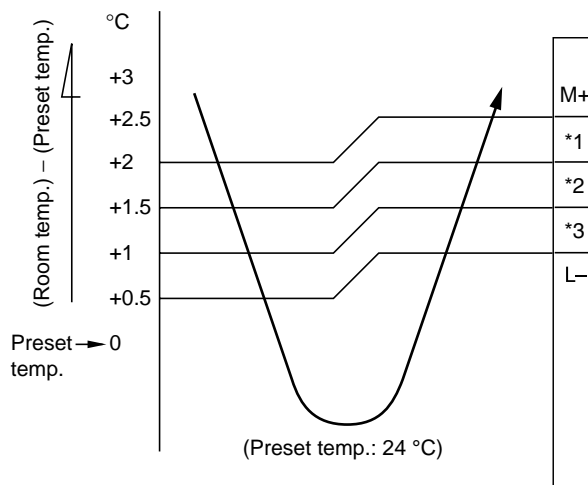

- NOTE 1 :** *1 : Fan speed = $(M + -L) \times 3/4 + L$
 *2 : Fan speed = $(M + -L) \times 2/4 + L$
 *3 : Fan speed = $(M + -L) \times 1/4 + L$

- 2 :** The Hi Power, ECO and COMFORT SLEEP operation can not be set
 (Linear approximation from M+ and L)

Fig. 7-3-1 Setting of air flow [FAN:AUTO]

7-3-2. Cooling operation

([MODE] button on the remote control is set to the cooling operation.)

- (1) The compressor, outdoor fan and operation display lamp are controlled as shown in Fig. 7-3-2.

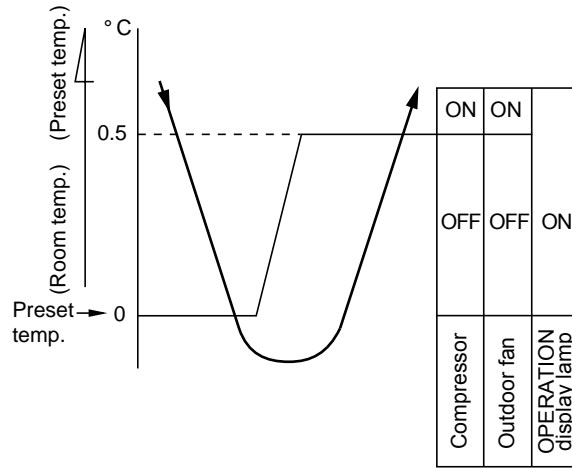
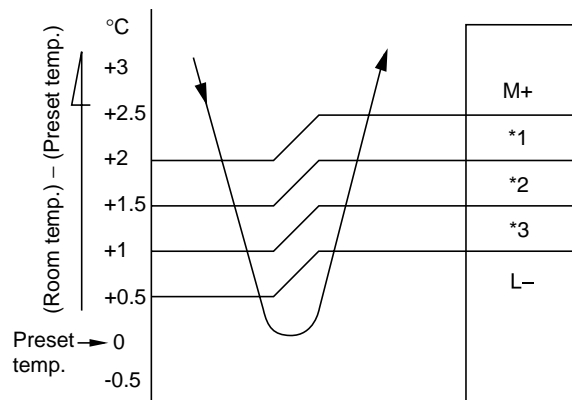

Fig. 7-3-2

- (2) When [FAN] button is set to AUTO, the indoor fan motor operates as shown in Fig. 7-3-3. When [FAN] button is set to LOW, LOW⁺, MED, MED⁺ or HIGH, the motor operates with a constant air flow.



- NOTE1 :** *1 : Fan speed = $(M + -L) \times 3/4 + L$
 *2 : Fan speed = $(M + -L) \times 2/4 + L$
 *3 : Fan speed = $(M + -L) \times 1/4 + L$
 (Linear approximation from M+ and L)

Fig. 7-3-3 Setting of air flow [FAN:AUTO]

7-3-3. Dry operation

([MODE] button on the remote control is set to the dry operation.)

- (1) The compressor, outdoor fan and operation display lamp are controlled as shown in Fig. 7-3-4.

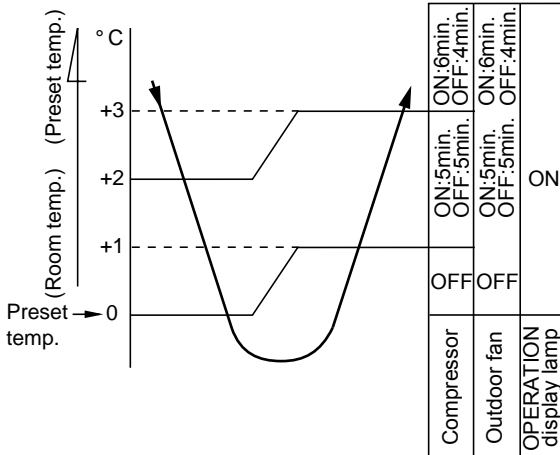

Fig. 7-3-4

- (2) The microprocessor turns the compressor on and off at the regular intervals (4 to 6 minutes). While the compressor is turning off, the indoor fan motor operates in the SUPER LOW position. The pattern of operation depending on the relation between room temperature and preset temperatures is shown in Fig. 7-3-5.

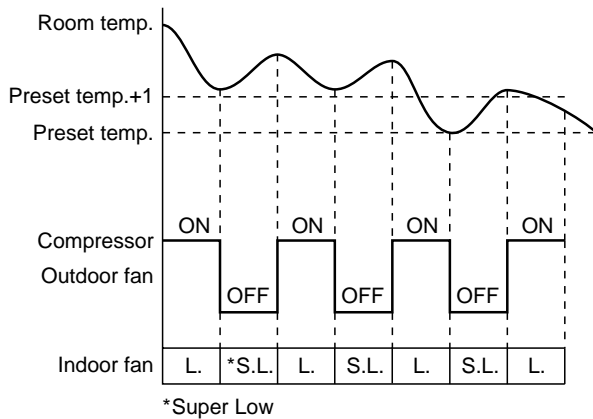

Fig. 7-3-5

- (3) [FAN] button on the remote control is set to AUTO only.
- (4) The ECO, COMFORT SLEEP, QUIET and Hi POWER operations can not be set.

7-3-4. Automatic operation

([MODE] button on the remote control is set to the automatic operation.)

- (1) One of 2 operations (Cooling or Fan only) is selected according to difference between the preset temperature and the room temperature at which the automatic operation has started, as shown in Fig. 7-3-6. The Fan only operation continues until the room temperature reaches a level at which another mode is selected.
- (2) Temporary Auto
When the [RESET] button on the indoor unit is pushed, the preset temperature is fixed at 24°C and the indoor unit is controlled as shown in Fig. 7-3-6.

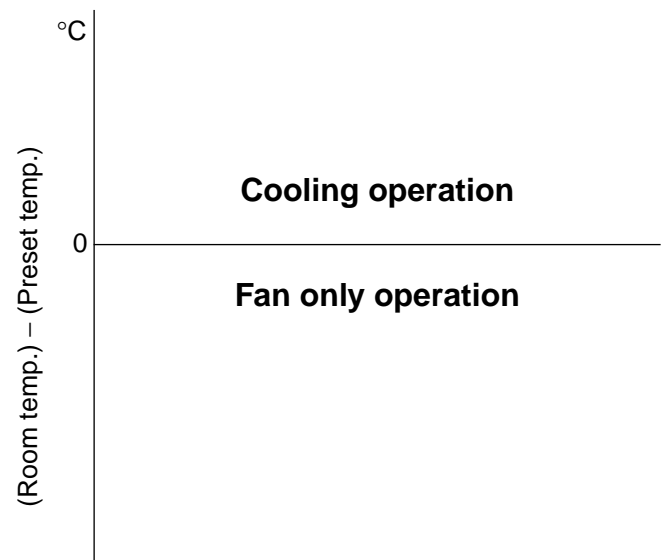

Fig. 7-3-6

7-4. Description of Safety and Reliability Prevention Function

7-4-1 Low-Temperature Limit Control

The microcontroller detects the indoor heat exchanger temperature to prevent the indoor heat exchanger from freezing. The compressor and outdoor fan motor are controlled as shown in Fig. 7-4-1

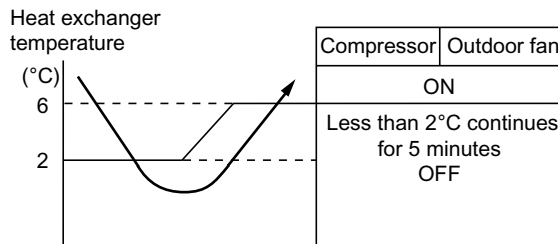

Fig. 7-4-1

7-5. One-Touch Operation

One touch comfort is the fully automated operation that is set according to the preferable condition in a region.

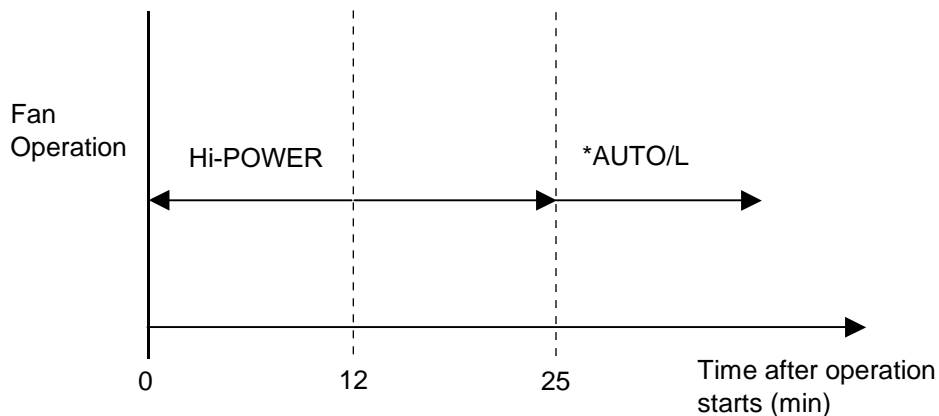

Fig. 7-5-1

*AUTO/L : Fan operates depends on the setting temperature and room temperature.

During the One Touch Comfort mode if the indoor unit receives any signal with other operation mode, the unit will cancel the comfort mode and operates according to the signal received.

Operation description.

When an indoor unit receives "One Touch Comfort Signal" from the remote controller, the indoor unit operates as following.

- 1) Air conditioner starts to operation when the signal is received, even if the air conditioner was OFF.
- 2) Operation mode is set Cooling mode.
- 3) Target temperature is 22°C.
- 4) Louver position is set swing.
- 5) Fan is controlled as diagram.

7-6. Hi POWER Operation ([Hi POWER] button on the remote control is pressed.)

When [Hi POWER] button is pressed while the indoor unit is in Auto or Cooling operation, Hi POWER mark is indicated on the display of the remote control and the unit operates as follows.

- (1) Automatic operation
 - The indoor unit operates in according to the current operation.
- (2) Cooling operation
 - The setting temperature drops 3°C.
(The value of the setting temperature on the remote control does not change.)
 - If the room temperature is higher than the setting temperature by 3.5°C or more, the horizontal louver moves to the Hi POWER position automatically. Then when the room temperature is 1°C less than the setting temperature the horizontal louver returns automatically.
 - FAN speed : [AUTO]
If the room temperature is higher than the setting temperature by 3.5°C or more, the air conditioner operates at maximum airflow level. If the room temperature is higher than the setting temperature by less than 3.5°C, the air conditioner operates at normal airflow level.
 - FAN speed : One of 5 levels
If the room temperature is higher than the setting temperature by 3.5°C or more, the air conditioner operates at higher consecutive airflow level. If the room temperature is higher than the setting temperature by less than 3.5°C, the air conditioner operates at normal airflow level.
 - The indoor unit's fan speed level increase 1 tap
- (3) The Hi POWER mode can not be set in Dry or Fan only operation.
- (4) The Hi POWER mode can memorize with timer function.

7-7. QUIET Operation

When the [QUIET] button is pressed, the fan of the indoor unit will be restricted the revolving speed at speed L– until the [QUIET] button is pressed once again (cancel Quiet mode).

Quiet mode is the system which, control the revolving speed of indoor fan to work constantly at lower than speed L. In addition, noise level of indoor unit is less than usual.

Remarks :

1. Quiet mode is unable to work in dry mode.
2. Quiet mode is appropriate to work with less cooling load condition. Because of the fan speed L– may cause not enough the cooling capacity.

7-8. ECO Operation

Cooling operation

- The preset temperature will increase 1°C after the ECO mode has operated for 1 hour and the temperature will increase another 1°C after the ECO mode has operated for 2 hour. (the value of the preset temperature on the remote control does not change.)
- The indoor fan speed is depend on presetting and can change every speed after setting ECO operation.

7-9. COMFORT SLEEP Operation

Cooling operation

- The preset temperature will increase 1°C after the comfort sleep mode has operated for 1 hour and the temperature will increase another 1°C after the comfort sleep mode has operated for 2 hour. (the value of the preset temperature on the remote control does not change)
- Press the [COMFORT SLEEP] button to select this function. The comfort sleep function will be activate together with Auto shut down function. Period of operation time can be selected by re-press the [COMFORT SLEEP] button. The period of operation time are follows.

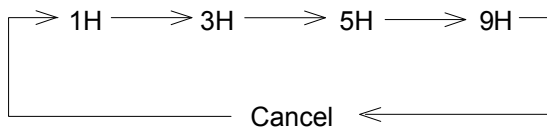

The principles of comfort sleep mode are:

- Quietness for more comfortable. When room temperature reach setting temperature.
- Save energy by changing room temperature automatically.
- The air condition can shut down by itself automatically. (follow to operation time that selected)

Remarks :

Comfort sleep mode will not operate in dry mode and fan only mode.

7-10. FILTER Check lamp

When the elapsed time reaches 1000 hours, the FILTER indicator lights. After cleaning the filters, turn off the FILTER indicator.

How to Turn Off FILTER Indicator

Press [RESET] button on the indoor unit or press filter button on the remote control.

NOTE :

If [RESET] button is pushed while the FILTER indicator is not lit, the indoor unit will start the automatic operation.

When you want a temporary operation while the FILTER lamp lights, press [RESET] button to turn off the FILTER lamp.

7-11. Auto Restart Function

This indoor unit is equipped with an automatic restarting function which allows the unit to restart operating with the set operating conditions in the event of a power supply being accidentally shut down.

The operation will resume without warning three minutes after power is restored.

This function is not set to work when shipped from the factory. Therefore it is necessary to set it to work.

7-11-1. How to Set the Auto Restart Function

To set the auto restart function, proceed as follows:

The power supply to the unit must be on ; the function will not set if the power is off.

Press the [RESET] button located in the center of the front panel continuously for three seconds.

The unit receives the signal and beeps three times.

The unit then restarts operating automatically in the event of power supply being accidentally shut down.

• When the unit is standby (Not operating)

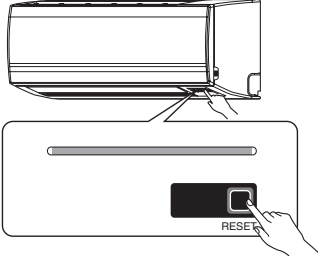
Operation	Motions
<p>Press [RESET] button for more than three seconds. (Less than 10 seconds)</p> 	<p>The unit is on standby.</p> <p style="text-align: center;">↓</p> <p>The unit starts to operate. The green indicator is on.</p> <p style="text-align: center;">↓ After approx. three seconds,</p> <p>The unit beeps three times The green indicator blinks and continues to operate. for 5 seconds.</p> <p>If the unit is not required to operate at this time, press [RESET] button once more or use the remote controller to turn it off.</p>

• When the unit is in operation

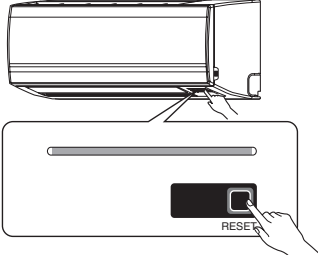
Operation	Motions
<p>Press [RESET] button for more than three seconds. (Less than 10 seconds)</p> 	<p>The unit is in operation. The green indicator is on.</p> <p style="text-align: center;">↓</p> <p>The unit stops operating. The green indicator is turned off.</p> <p style="text-align: center;">↓ After approx. three seconds,</p> <p>The unit beeps three times. The green indicator blinks for 5 seconds.</p> <p>If the unit is required to operate at this time, press [RESET] button once more or use the remote controller to turn it on.</p>

7-11-2. How to Cancel the Auto Restart Function

To cancel auto restart function, proceed as follows :

Repeat the setting procedure : the unit receives the signal and beeps three times.

The unit will be required to be turned on with the remote controller after the main power supply is turned off.

• When the system is on stand-by (not operating)

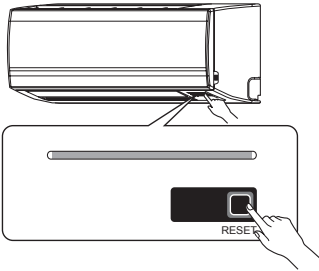
Operation	Motions
<p>Press [RESET] button for more than three seconds. (Less than 10 seconds)</p> 	<p>The unit is on standby.</p> <p style="text-align: center;">↓</p> <p>The unit starts to operate. The green indicator is on.</p> <p style="text-align: center;">↓ After approx. three seconds,</p> <p>The unit beeps three times and continues to operate.</p> <p>If the unit is not required to operate at this time, press [RESET] button once more or use the remote controller to turn it off.</p>

• When the system is operating

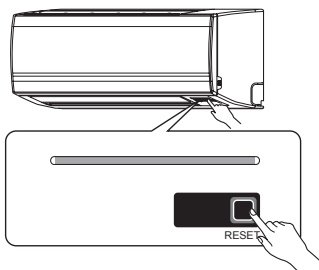
Operation	Motions
<p>Press [RESET] button for more than three seconds. (Less than 10 seconds)</p> 	<p>The unit is in operation. The green indicator is on.</p> <p style="text-align: center;">↓</p> <p>The unit stops operating. The green indicator is turned off.</p> <p style="text-align: center;">↓ After approx. three seconds,</p> <p>The unit beeps three times.</p> <p>If the unit is required to operate at this time, press [RESET] button once more or use the remote controller to turn it on.</p>

7-11-3. Power Failure During Timer Operation

When the unit is turned off because of power failure during timer operation, the timer operation is cancelled. In that case, set the timer operation again.

NOTE :

The Everyday Timer is reset while a command signal can be received from the remote controller even if it stopped due to a power failure.

7-12. Self-Cleaning Operation

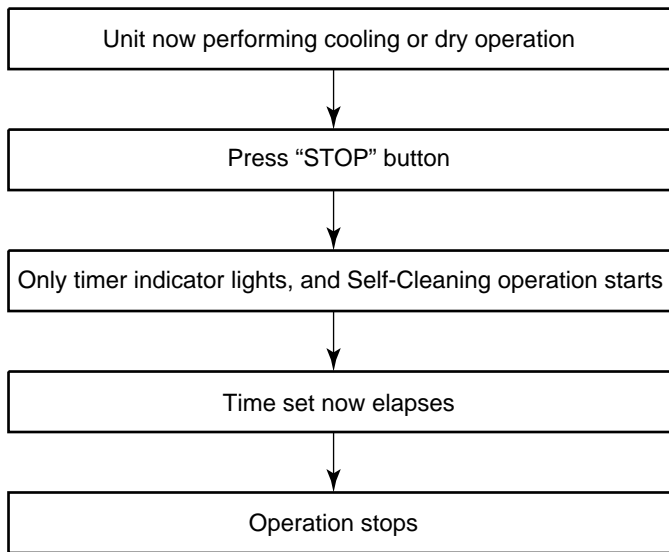

- During Self-Cleaning operations: The louver opens slightly. The indoor fan operates continuously at a speed of SL rpm.

Self-Cleaning operation times

	Operation time	Self-Cleaning operation time
Cooling: Auto (cooling) Dry	Up to 10 minutes	No Self-Cleaning operation performed (0 minute)
	10 minutes or longer	20 minutes.
Auto (fan only)	No Self-Cleaning operation performed	
Shutdown		

- To stop an ongoing Self-Cleaning operation at any time Press the start/stop button on the remote controller twice during the Self-Cleaning operation. [After pressing the button for the first time, press it for the second time without delay (within 10 minutes)].

1. Purpose

The Self-Cleaning operation is to minimize the growth of mold, bacteria etc. by running the fan and drying so as to keep the inside of the air conditioner clean.

Self-Cleaning operation

When the cooling or dry operation shuts down, the unit automatically starts the Self-Cleaning operation which is then performed for the specified period based on duration of the operation which was performed prior to the shutdown, after which the Self-Cleaning operation stops.

2. Operation

- 1) When the stop signal from the remote controller or timer-off function is received, only the timer indicator light.
- 2) The period of the Self-Cleaning operation is determined by the duration of the operation performed prior to the reception of the stop code.
- 3) After the Self-Cleaning operation has been performed for the specified period, the unit stops operation.

7-12-1. Self-Cleaning diagram

Operation display	ON	OFF	OFF
FCU fan	ON rpm is depend on presetting.	ON (SL)	OFF
FCU louver	OPEN	OPEN (12.7°)	CLOSE
Timer display	ON or OFF depend on presetting of timer function.	ON	ON or OFF depend on presetting of timer function.
Compressor	ON or OFF depend on presetting per room temperature.	OFF	OFF
CDU fan	ON or OFF depend on presetting per room temperature.	OFF	OFF

Operation time →

Turn off by remote controller or timer-off function. Automatically turn-off.

7-12-2. Self-Cleaning function release

How to cancel Self-Cleaning function

To cancel the Self-Cleaning function, proceed as follows:

- Press [RESET] button one time or use remote control to turn on air conditioner. Display will show in green color.
- Hold down the [RESET] button for more than 20 seconds. (The air conditioner will stop suddenly when the [RESET] is pressed but keep holding it continue. The will beep 3 times in the first 3 seconds but it is not related to Self-Cleaning function)
- After holding about 20 seconds, the air conditioner will beep 5 times without any blinking of display.
- The Self-Cleaning Operation had been cancelled.

Remark

Presetting of Self-Cleaning function above, AUTO-RESTART function had been cancelled. To set AUTO-RESTART again.

How to set Self-Cleaning function

To set the Self-Cleaning function, proceed as follows.

- Press [RESET] button one time or use remote control to turn on air conditioner. Display will show in green color.
- Hold down the [RESET] button for more than 20 seconds. (The air conditioner will stop suddenly when the [RESET] is pressed but keep holding it continue. Then will beep 3 times is the first 3 seconds but it is not related to Self-Cleaning function)
- After holding about 20 seconds, the air conditioner will beep 5 times and OPERATION display blinks 5 times.
- The Self-Cleaning function had been set.

Remark

Presetting of Self-Cleaning function above, AUTO-RESTART function had been cancelled. To set AUTO-RESTART again.

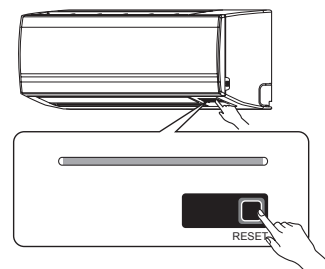

8. INSTALLATION PROCEDURE

8-1. Safety Cautions

For general public use

power supply cord of parts of appliance for Indoor use shall be at least polychloroprene sheathed flexible cord (design H07 RN-F), or cord designation 245 IEC66 (1.5 mm² or more). (Shall be installed in accordance with national wiring regulations.)

CAUTION

To Disconnect the Appliance from the Main Power Supply

This appliance must be connected to the main power supply by means of a circuit breaker or a switch with a contact separation of at least 3 mm in all poles

If this is not possible, a power supply plug with earth must be used. This plug must be easily accessible after installation. The plug must be disconnected from the power supply socket in order to disconnect the appliance completely from the mains.

DANGER

- FOR USE BY QUALIFIED PERSONS ONLY.
- TURN OFF MAIN POWER SUPPLY BEFORE ATTEMPTING ANY ELECTRICAL WORK. MAKE SURE ALL POWER SWITCHES ARE OFF. FAILURE TO DO SO MAY CAUSE ELECTRIC SHOCK.
- CONNECT THE CONNECTING CABLE CORRECTLY. IF THE CONNECTING CABLE IS CONNECTED WRONGLY, ELECTRIC PARTS MAY BE DAMAGED.
- CHECK THE EARTH WIRE THAT IT IS NOT BROKEN OR DISCONNECTED BEFORE INSTALLATION.
- DO NOT INSTALL NEAR CONCENTRATIONS OF COMBUSTIBLE GAS OR GAS VAPORS. FAILURE TO FOLLOW THIS INSTRUCTION CAN RESULT IN FIRE OR EXPLOSION.
- TO PREVENT OVERHEATING THE INDOOR UNIT AND CAUSING A FIRE HAZARD, PLACE THE UNIT WELL AWAY (MORE THAN 2 M) FROM HEAT SOURCES SUCH AS RADIATORS, HEATERS, FURNACE, STOVES, ETC.
- WHEN MOVING THE AIR-CONDITIONER FOR INSTALLING IT IN ANOTHER PLACE AGAIN, BE VERY CAREFUL NOT TO GET THE SPECIFIED REFRIGERANT WITH ANY OTHER GASEOUS BODY INTO THE REFRIGERATION CYCLE. IF AIR OR ANY OTHER GAS IS MIXED IN THE REFRIGERANT, THE GAS PRESSURE IN THE REFRIGERATION CYCLE BECOMES ABNORMALLY HIGH AND IT RESULTINGLY CAUSES BURST OF THE PIPE AND INJURIES ON PERSONS.
- IN THE EVENT THAT THE REFRIGERANT GAS LEAKS OUT OF THE PIPE DURING THE INSTALLATION WORK, IMMEDIATELY LET FRESH AIR INTO THE ROOM. IF THE REFRIGERANT GAS IS HEATED BY FIRE OR SOMETHING ELSE, IT CAUSES GENERATION OF POISONOUS GAS.

WARNING

- Never modify this unit by removing any of the safety guards or bypassing any of the safety interlock switches.
- Do not install in a place which cannot bear the weight of the unit.
Personal injury and property damage can result if the unit falls.
- Before doing the electrical work, attach an approved plug to the power supply cord.
Also, make sure the equipment is properly earthed.
- Appliance shall be installed in accordance with national wiring regulations.
If you detect any damage, do not install the unit. Contact your TOSHIBA dealer immediately.

CAUTION

- Exposure of unit to water or other moisture before installation could result in electric shock.
Do not store it in a wet basement or expose to rain or water.
- After unpacking the unit, examine it carefully for possible damage.
- Do not install in a place that can increase the vibration of the unit. Do not install in a place that can amplify the noise level of the unit or where noise and discharged air might disturb neighbors.
- To avoid personal injury, be careful when handling parts with sharp edges.
- Please read this installation manual carefully before installing the unit. It contains further important instructions for proper installation.

REQUIREMENT OF REPORT TO THE LOCAL POWER SUPPLIER

Please make absolutely sure that the installation of this appliance is reported to the local power supplier before installation. If you experience any problems, or if the installation is not accepted by the supplier, the service agency will take adequate countermeasures.

8-2. Installation Diagram of Indoor and Outdoor Units

RAS-13SKPX-IN-1

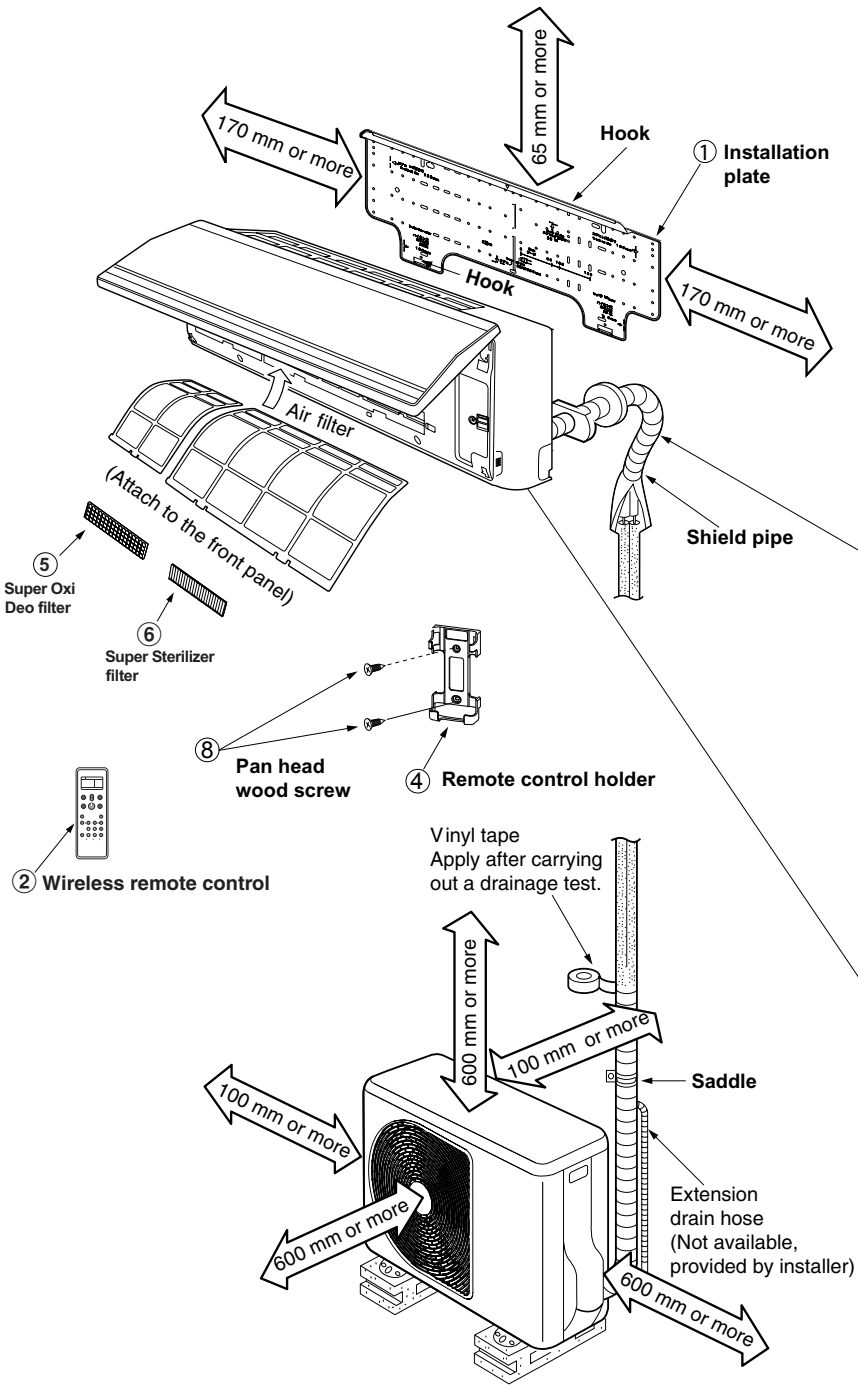

For the rear left and left piping

Wall

Insert the cushion between the indoor unit and wall, and tilt the indoor unit for better operation.

Do not allow the drain hose to get slack.

Cut the piping hole sloped slightly.

Make sure to run the drain hose sloped downward.

The auxiliary piping can be connected to the left, rear left, rear right, right, bottom right or bottom left.

Right
Rear right
Bottom right
Rear left
Bottom left

Insulate the refrigerant pipes separately with insulation, not together.

6 mm thick heat resisting polyethylene foam

Before installing the wireless remote controller

- **Loading Batteries**
 1. Remove the battery cover.
 2. Insert 2 new batteries (AAA type) following the (+) and (-) positions.

(2) Wireless remote controller (3) Batteries

RAS-13SKP-E

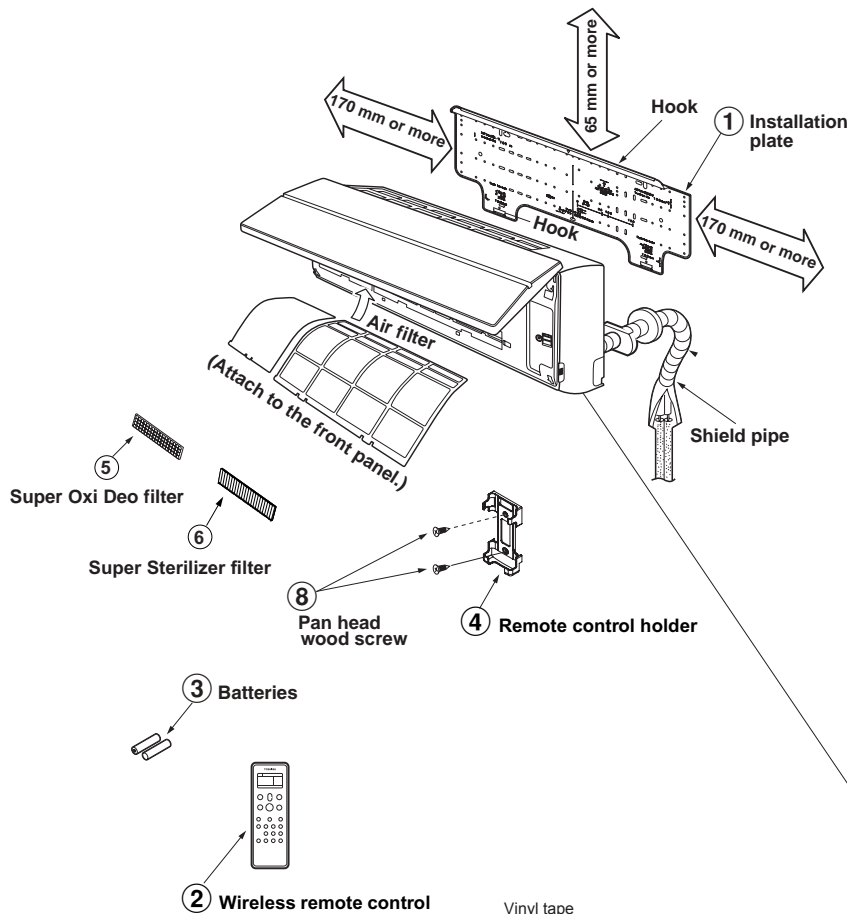

For the rear left and left piping

Wall

Insert the cushion between the indoor unit and wall, and tilt the indoor unit for better operation.

Do not allow the drain hose to get slack.

Cut the piping hole sloped slightly.

Make sure to run the drain hose sloped downward.

The auxiliary piping can be connected to the left, rear left, rear right, right, bottom right or bottom left.

Right

Rear right

Bottom right

Rear left

Bottom left

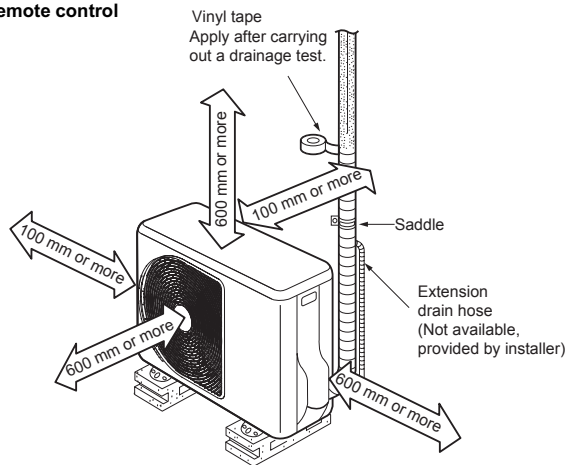

Insulate the refrigerant pipes separately with insulation, not together.

6 mm thick heat resisting polyethylene foam

Before installing the wireless remote controller

- Loading Batteries
 1. Remove the battery cover.
 2. Insert 2 new batteries (AAA type) following the (+) and (-) positions.

3 Batteries

2 Wireless remote controller

8-3. Installation

8-3-1. Optional installation parts

Part Code	Parts name	Q'ty
Ⓐ	Refrigerant piping Liquid side : $\varnothing 6.35$ mm Gas side : $\varnothing 12.70$ mm	One each
Ⓑ	Pipe insulating material (polyethylene foam, 6 mm thick)	1
Ⓒ	Putty, PVC tapes	One each

<Fixing bolt arrangement of outdoor unit>

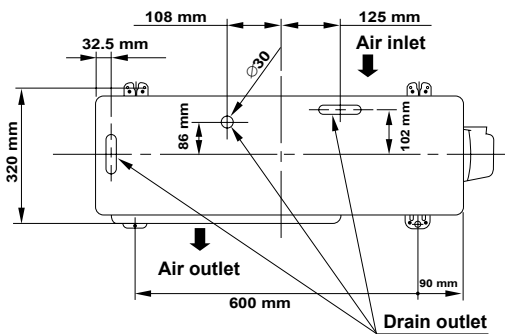

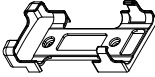

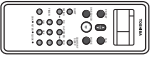





Fig. 8-3-1

- ❑ Secure the outdoor unit with fixing bolts and nuts if the unit is likely to be exposed to a strong wind.
- ❑ Use $\varnothing 8$ mm or $\varnothing 10$ mm anchor bolts and nuts.

8-3-2. Accessory and installation parts

Part No.	Part name (Q'ty)	Part No.	Part name (Q'ty)	Part No.	Part name (Q'ty)
①	 Installation plate x 1	④	 Remote control holder x 1	⑦	 Mounting screw $\varnothing 4 \times 25 \ell \times 6$
②	 Wireless remote control x 1	⑤	 Super Oxi Deo filter x 1	⑧	 Pan head wood screw $\varnothing 3.1 \times 16 \ell \times 2$
③	 Battery x 2	⑥	 Super Sterilizer filter x 1		

Others

Name
Owner's manual
Installation manual

8-4. Indoor Unit

8-4-1. Installation place

- A place which provides the spaces around the indoor unit as shown in the diagram in part 8-2.
- A place where there is no obstacle near the air inlet and outlet.
- A place that allows easy installation of the piping to the outdoor unit.
- A place which allows the front panel to be opened.
- The indoor unit shall be installed as top of the indoor unit comes to at least 2 m height. Also, it must be avoided to put anything on the top of the indoor unit.

CAUTION

- Direct sunlight to the indoor unit's wireless receiver should be avoided.
- The microprocessor in the indoor unit should not be too close to RF noise sources.
(For details, see the owner's manual.)

<Remote control>

- A place where there are no obstacles such as a curtain that may block the signal from the indoor unit.
- Do not install the remote control in a place exposed to direct sunlight or close to a heating source, such as a stove.
- Keep the remote control at least 1 m apart from the nearest TV set or stereo equipment. (This is necessary to prevent image disturbances or noise interference.)
- The location of the remote control should be determined as shown below.

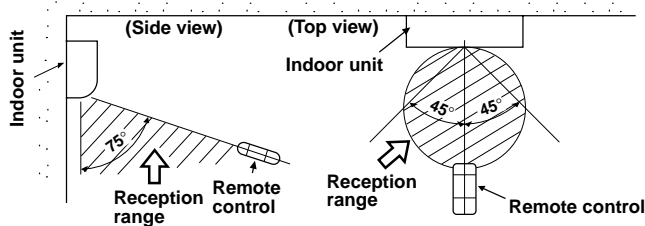

Fig. 8-4-1

8-4-2. Cutting a hole and mounting installation plate

<Cutting a hole>

When installing the refrigerant pipes from the rear.

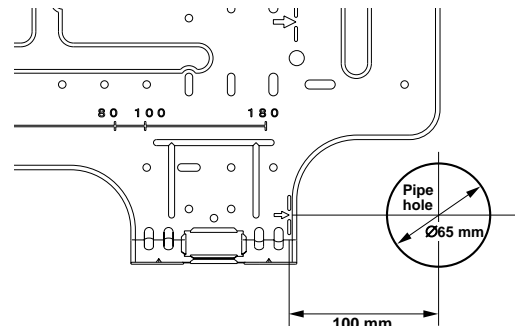

Fig. 8-4-2

1. After determining the pipe hole position on the mounting plate (→), drill the pipe hole (Ø65 mm) at a slight downward slant to the outdoor side.

NOTE

- When drilling a wall that contains a metal lath, wire lath or metal plate, be sure to use a pipe hole brim ring sold separately.

<Mounting the installation plate>

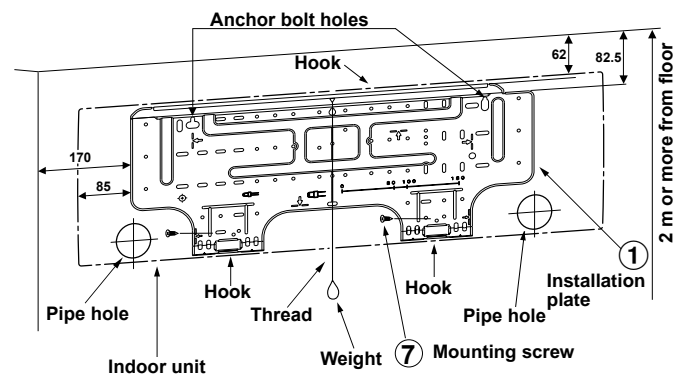

Fig. 8-4-3

<When the installation plate is directly mounted on the wall>

1. Securely fit the installation plate onto the wall by screwing it in the upper and lower parts to hook up the indoor unit.
2. To mount the installation plate on a concrete wall with anchor bolts, utilize the anchor bolt holes as illustrated in the above figure.
3. Install the installation plate horizontally in the wall.

CAUTION

When installing the installation plate with a mounting screw, do not use the anchor bolt hole. Otherwise the unit may fall down and result in personal injury and property damage.

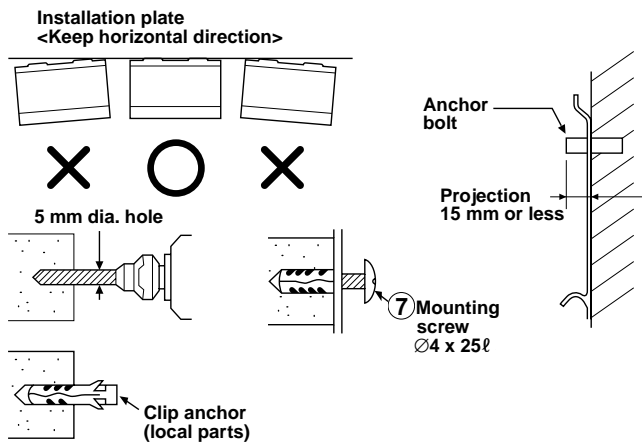

Fig. 8-4-4

CAUTION

Failure to firmly install the unit may result in personal injury and property damage if the unit falls.

- In case of block, brick, concrete or similar type walls, make 5 mm dia. holes in the wall.
- Insert clip anchors for appropriate mounting screws ⑦.
- Secure four corners and lower parts of the installation plate with 4 to 6 mounting screws to install it.

8-4-3. Electrical work

1. The supply voltage must be the same as the rated voltage of the air conditioner.
2. Prepare the power source for exclusive use with the air conditioner.

CAUTION

- This appliance can be connected to the mains in either of the following two ways.
 - (1) Connection to fixed wiring:
A switch or circuit breaker which disconnects all poles and has a contact separation of at least 3 mm must be incorporate in the fixed wiring. An approved circuit breaker or switches must used.
 - (2) Connection with power supply plug:
Attach power supply plug with power cord and plug it into wall outlet. An approved power supply cord and plug must be used.

NOTE

- Ensure all wiring is used within its electrical rating.

Model	13 Series	
Power source	50 Hz, 220 V Single phase	
Maximum running current	7.5A	12A
Plug socket & fuse rating	16A	
Power cord	1.5 mm ² or more	

8-4-4. Wiring connection

<How to connect the connecting cable>

Wiring of the connecting cable can be carried out without removing the front panel.

1. Remove the air inlet grille.
Open the air inlet grille upward and pull it toward you.
2. Remove the terminal cover and cord clamp.
3. Insert the connecting cable (according to the local cords) into the pipe hole on the wall.
4. Take out the connecting cable through the cable slot on the rear panel so that it protrudes about 15 cm from the front.
5. Insert the connecting cable fully into the terminal block and secure it tightly with screws.
6. Tightening torque : 1.2 N·m (0.12 kgf·m)
7. Secure the connecting cable with the cord clamp.
8. Fix the terminal cover, rear plate bushing and air inlet grille on the indoor unit.

CAUTION

- Be sure to refer to the wiring system diagram labeled inside the front panel.
- Check local electrical cords and also any specific wiring instructions or limitations.

<How to install the air inlet grille on the indoor unit>

- When attaching the air inlet grille, the contrary of the removed operation is performed.

RAS-13SKPX-IN-1

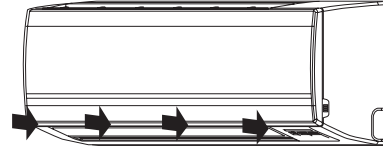

Fig. 8-4-11

RAS-13SKP-E

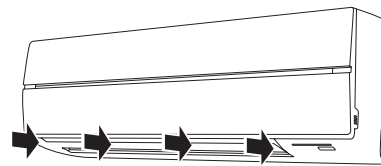

Fig. 8-4-12

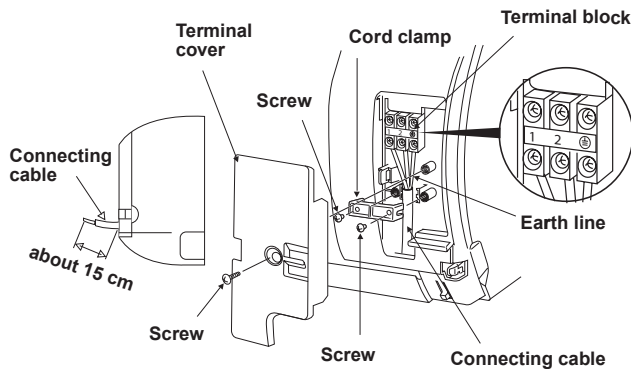

Fig. 8-4-9

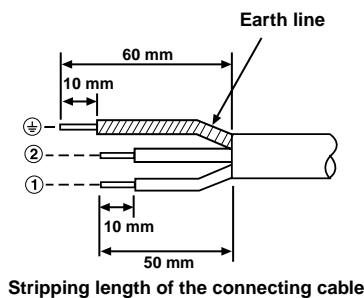

Fig. 8-4-10

NOTE

- Use stranded wire only.
- Wire type : H07 RN-F or more

8-4-5. Piping and drain hose installation

<Piping and drain hose forming>

* Since dewing results in a machine trouble, make sure to insulate both the connecting pipes. (Use polyethylene foam as insulating material.)

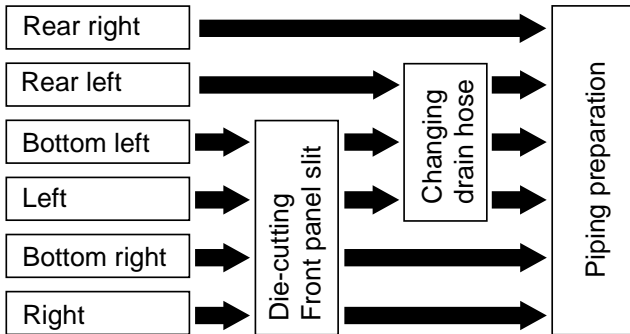

1. Die-cutting front panel slit

Cut out the slit on the left or right side of the front panel for the left or right connection and the slit on the bottom left or right side of the front panel for the bottom left or right connection with a pair of nippers.

2. Changing drain hose

For leftward connection, bottom leftward connection and rear leftward connection's piping, it is necessary to change the drain hose and drain cap.

How to remove the drains cap

Clip drain cap by needle-nose plier, and pull out.

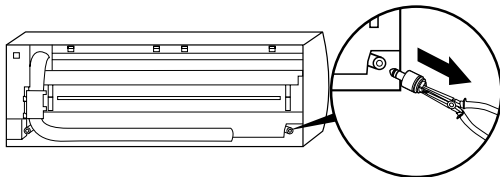

Fig. 8-4-12

How to install the drain hose

Firmly insert drain hose connecting part until hitting on a heat insulator and fix it with a screw.

How to remove the drain hose

- The drain hose can be removed by take off screw, after that twisting and pulling.
- When removing the drain hose, be careful of any sharp edges of steel plate. The edges can cause injuries.

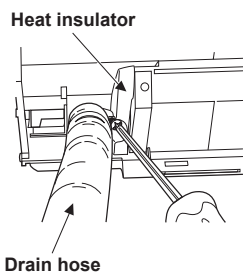

Fig.8-4-13

How to fix the drains cap

- 1) Insert hexagonal wrench (4 mm) in a center head.

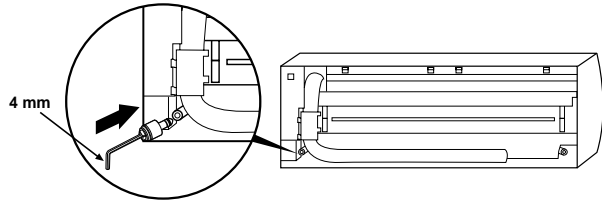

Fig. 8-4-14

- 2) Firmly insert drains cap.

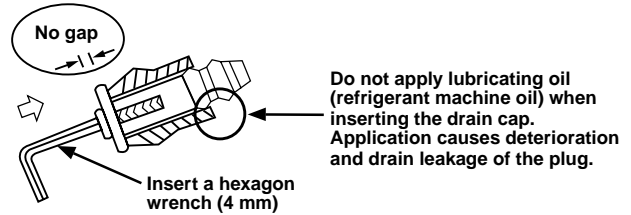

Fig. 8-4-15

CAUTION

Firmly insert the drain hose and drain cap; otherwise, water may leak.

<In case of right or left piping>

- After scribing slits of the front panel with a knife or a making-off pin, cut them with a pair of nippers or an equivalent tool.

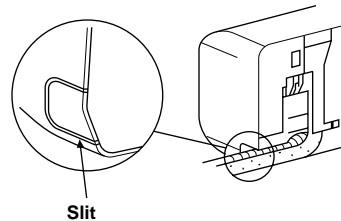

Fig. 8-4-16

<In case of bottom right or bottom left piping>

- After scribing slits of the front panel with a knife or a making-off pin, cut them with a pair of nippers or an equivalent tool.

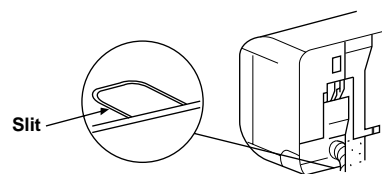

Fig. 8-4-17

<Left-hand connection with piping>

Bend the connecting pipe so that it is laid within 43 mm above the wall surface. If the connecting pipe is laid exceeding 43 mm above the wall surface, the indoor unit may unstably be set on the wall. When bending the connecting pipe, make sure to use a spring bender so as not to crush the pipe.

Bend the connection pipe within a radius of 30 mm.

To connect the pipe after installation of the unit (figure)

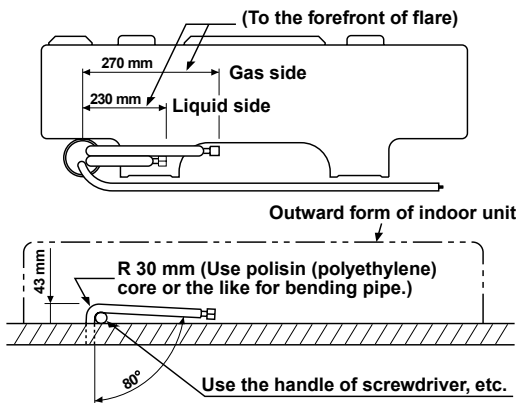

Fig. 8-4-18

NOTE

If the pipe is bent incorrectly, the indoor unit may unstably be set on the wall. After passing the connecting pipe through the pipe hole, connect the connecting pipe to the auxiliary pipes and wrap the facing tape around them.

CAUTION

- Bind the auxiliary pipes (two) and connecting cable with facing tape tightly. In case of leftward piping and rear-leftward piping, bind the auxiliary pipes (two) only with facing tape.

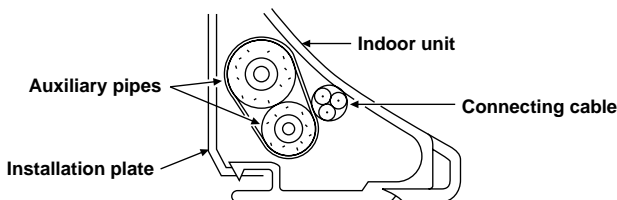

- Carefully arrange pipes so that any pipe does not stick out of the rear plate of the indoor unit.
- Carefully connect the auxiliary pipes and connecting pipes to each other and cut off the insulating tape wound on the connecting pipe to avoid double-taping at the joint, moreover, seal the joint with the vinyl tape, etc.
- Since dewing results in a machine trouble, make sure to insulate both the connecting pipes. (Use polyethylene foam as insulating material.)
- When bending a pipe, carefully do it, not to crush it.

8-4-6. Indoor unit fixing

1. Pass the pipe through the hole in the wall, and hook the indoor unit on the installation plate at the upper hooks.
2. Swing the indoor unit to right and left to confirm that it is firmly hooked up on the installation plate.
3. While pressing the indoor unit onto the wall, hook it at the lower part on the installation plate. Pull the indoor unit toward you to confirm that it is firmly hooked up on the installation plate.

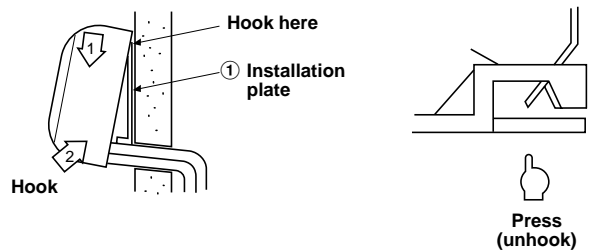

Fig. 8-4-19

- For detaching the indoor unit from the installation plate, pull the indoor unit toward you while pushing its bottom up at the specified parts.

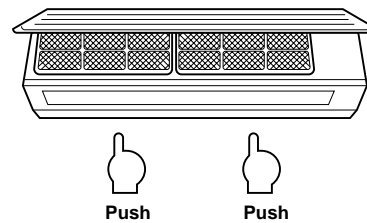

Fig. 8-4-20

8-4-7. Drainage

1. Run the drain hose sloped downwards.

NOTE

- Hole should be made at a slight downward slant on the outdoor side.

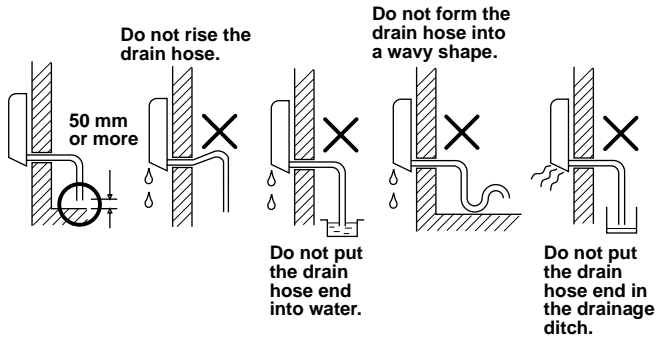

Fig. 8-4-21

2. Put water in the drain pan and make sure that the water is drained out of doors.
3. When connecting extension drain hose, insulate the connecting part of extension drain hose with shield pipe.

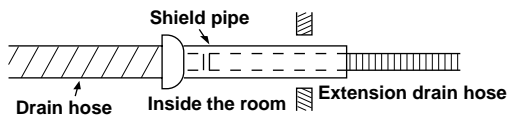

Fig. 8-4-22

CAUTION

Arrange the drain pipe for proper drainage from the unit.
Improper drainage can result in dew-dropping.

This air conditioner has the structure designed to drain water collected from dew, which forms on the back of the indoor unit, to the drain pan. Therefore, do not store the power cord and other parts at a height above the drain guide.

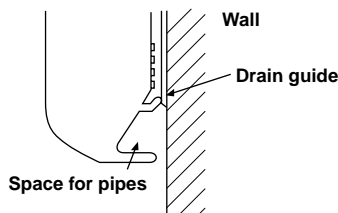

Fig. 8-4-23

8-5. Outdoor Unit

8-5-1. Installation place

- A place which provides the spaces around the outdoor unit as shown in the left diagram.
- A place which can bear the weight of the outdoor unit and does not allow an increase in noise level and vibration.
- A place where the operation noise and discharged air do not disturb your neighbors.
- A place which is not exposed to a strong wind.
- A place free of a leakage of combustible gases.
- A place which does not block a passage.
- When the outdoor unit is to be installed in an elevated position, be sure to secure its feet.
- An allowable length of the connecting pipe is up to 15 m (13 series).
- An allowable height level is up to 6 m (13 series).
- A place where the drain water does not raise any problem.

CAUTION

1. Install the outdoor unit without anything blocking the air discharging.
2. When the outdoor unit is installed in a place exposed always exposed to strong wind like a coast or on a high storey of a building, secure the normal fan operation using a duct or a wind shield.
3. In particularly windy areas, install the unit such as to avoid admission of wind.
4. Installation in the following places may result in trouble.

Do not install the unit in such places.

- A place full of machine oil.
- A saline-place such as the coast.
- A place full of sulfide gas.
- A place where high-frequency waves are likely to be generated as from audio equipment, welders, and medical equipment.

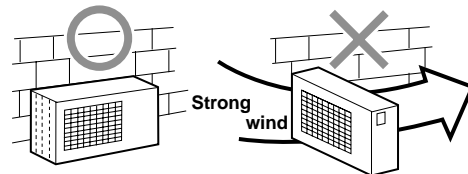

Fig. 8-5-1

8-5-2. Refrigerant piping connection

1. Cut the pipe with a pipe cutter.

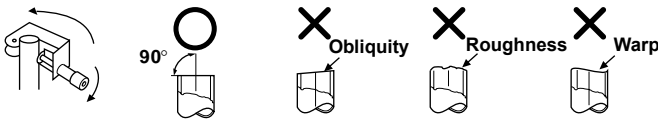

Fig. 8-5-2

2. Insert a flare nut into the pipe, and flare the pipe.

- **Projection margin in flaring : A (Unit : mm)**

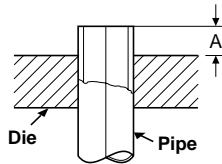

Fig. 8-5-3

Outer dia. of copper pipe	Tightening torque
Ø6.35	16 to 18 (1.6 to 1.8 kgf·m)
Ø9.52	30 to 42 (3.0 to 4.2 kgf·m)
Ø12.70	50 to 62 (5.0 to 6.2 kgf·m)

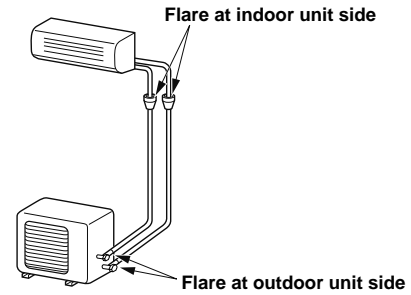

Fig. 8-5-4

Outer dia. of copper pipe	A	
	Rigid	Imperial
6.35	0.5 to 1.0	1.0 to 1.5
9.52	0.5 to 1.0	1.0 to 1.5
12.70	0.5 to 1.0	1.5 to 2.0

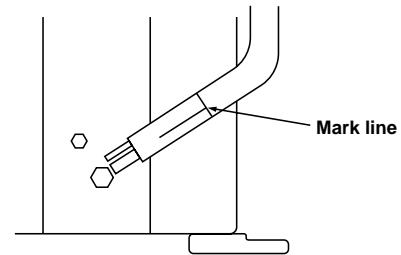
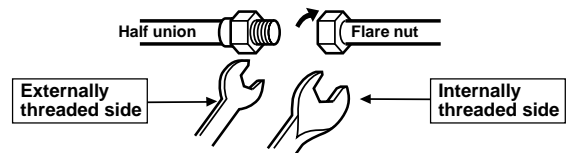

Fig. 8-5-5

<Tightening connection>

Align the centers of the connecting pipes and tighten the flare nut as far as possible with your fingers. Then tighten the nut with a spanner and torque wrench as shown in the figure.



Use a wrench to secure. Use a torque wrench to tighten.

Fig. 8-5-6

CAUTION

- Do not apply excess torque.
- Otherwise, the nut may crack depending on the conditions.

CAUTION

• KEEP IMPORTANT 4 POINTS FOR PIPING WORK

- (1) Take away dust and moisture (Inside of the connecting pipes.)
- (2) Tight connection (between pipes and unit)
- (3) Evacuate the air in the connecting pipes using VACUUM PUMP.
- (4) Check gas leak (connected points)

8-5-3. Evacuating

After the piping has been connected to the indoor unit, you can perform the air purge together at once.

AIR PURGE

Evacuate the air in the connecting pipes and in the indoor unit using a vacuum pump. Do not use the refrigerant in the outdoor unit. For details, see the manual of the vacuum pump.

<Using a vacuum pump>

Be sure to use a vacuum pump with counter-flow prevention function so that inside oil of the pump does not flow backward into pipes of the air conditioner when the pump stops.

1. Connect the charge hose from the manifold valve to the service port of the gas side packed valve.
2. Connect the charge hose to the port of the vacuum pump.
3. Open fully the low pressure side handle of the gauge manifold valve.
4. Operate the vacuum pump to start evacuating. Perform evacuating for about 15 minutes if the piping length is 20 meters. (15 minutes for 20 meters) (assuming a pump capacity of 27 liters per minute.) Then confirm that the compound pressure gauge reading is -101 kPa (76 cmHg).
5. Close the low pressure side valve handle of gauge manifold.
6. Open fully the valve stem of the packed valves (both sides of Gas and Liquid).
7. Remove the charging hose from the service port.
8. Securely tighten the caps on the packed valves.

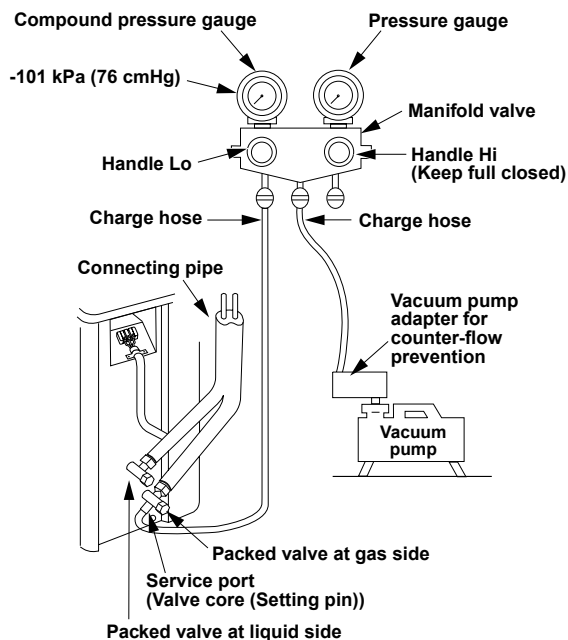

Fig. 8-5-7

<Packed valve handling precautions>

- □ Open the valve stem all the way out; but do not try to open it beyond the stopper.
- □ Securely tighten the valve stem cap with torque in the following table:

Gas side (Ø12.70 mm)	50 to 62 N·m (5.0 to 6.2 kgf·m)
Gas side (Ø9.52 mm)	30 to 42 N·m (3.0 to 4.2 kgf·m)
Liquid side (Ø6.35 mm)	16 to 18 N·m (1.6 to 1.8 kgf·m)
Service port	9 to 10 N·m (0.9 to 1.0 kgf·m)

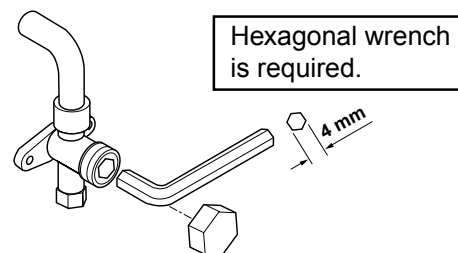

Fig. 8-5-8

8-5-4. Wiring connection

1. Remove the valve cover from the outdoor unit.
2. Connect the connecting cable to the terminal as identified with their respective matched numbers on the terminal block of indoor and outdoor unit.
3. When connecting the connecting cable to the outdoor unit terminal, make a loop as shown in the installation diagram of indoor and outdoor unit, to prevent water coming in the outdoor unit.
4. Insulate the unused cords (conductors) from any water coming in the outdoor unit. Proceed them so that they do not touch any electrical or metal parts.

<Stripping length of connecting cable>

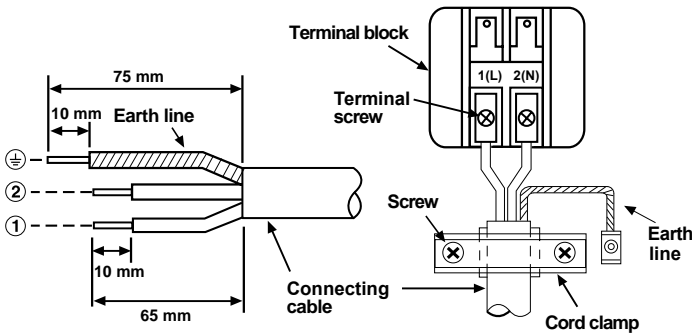

Fig. 8-5-9

CAUTION

- Wrong wiring connection may cause some electrical parts burn out.
- Be sure to comply with local codes on running the wire from indoor unit to outdoor unit (size of wire and wiring method etc.)
- Every wire must be connected firmly.

NOTE

- Wire type: H07 RN-F or 245 IEC66 (2.0 mm² or more)

8-6. How to Set Remote Control Selector Switch

When two indoor units are installed in separated rooms, there is no need to change the selector switch.

<Remote control selector switch>

- When two indoor units are installed in the same room or adjacent two rooms, if operating a unit, two units may receive the remote control signal simultaneously and operate. In this case, the operation can be preserved by setting either one indoor unit or remote control to B setting. (Both are set to A setting in factory shipment.)
- The remote control signal is not received when the settings of indoor unit and remote control are different.
- There is no relation between A setting/B setting and A room/B room when connecting the piping and cables.

<Remote control A-B selection>

To separate using of remote control for each indoor unit in case of 2 air conditioners are installed nearby.

Remote Control B Setup.

1. Press RESET button on the indoor unit to turn the air conditioner ON.
2. Point the remote control at the indoor unit.
3. Push and hold CHK ● button on the Remote Control by the tip of the pencil. "00" will be shown on the display
4. Press ● MODE during pushing CHK ●. "B" will show on the display and "00" will disappear and the air conditioner will turn OFF. The Remote Control B is memorized.

NOTE : 1. Repeat above step to reset Remote Control to be A.

2. Remote Control A has not "A" display.
3. Default setting of Remote Control from factory is A.

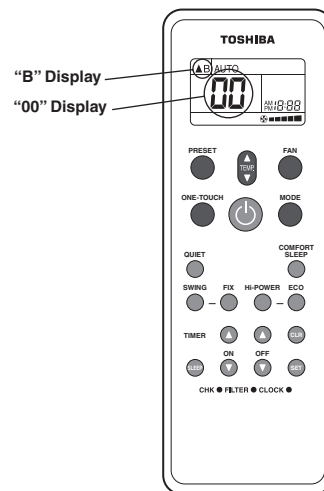

Fig. 8-6-1

8-7. Others

8-7-1. Gas leak test

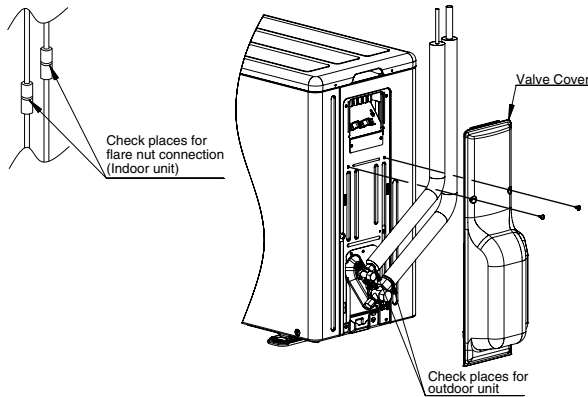

Fig. 8-7-1

- Check the flare nut connections for the gas leak with a gas leak detector or soap water.

8-7-2. Test operation

To switch the TEST RUN (COOL) mode, press RESET button for 10 sec.
(The beeper will make a short beep.)

RAS-13SKPX-IN-1

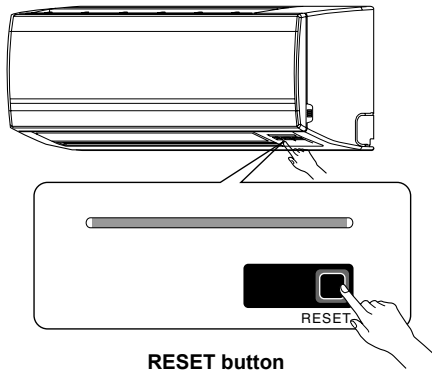

RESET button

Fig. 8-7-2

RAS-13SKP-E

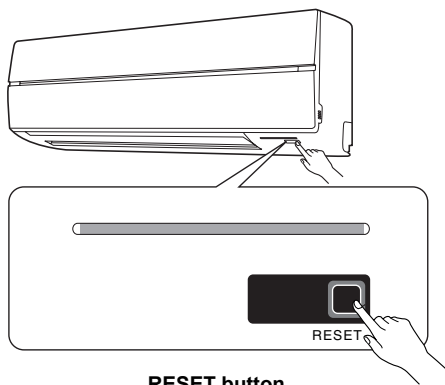

RESET button

Fig. 8-7-3

8-7-3. Auto restart setting

This product is designed so that, after a power failure, it can restart automatically in the same operating mode as before the power failure.

Information

The product was shipped with Auto Restart function in the off position. Turn it on as required.

<How to set the auto restart>

- Press and hold the RESET button for about 3 seconds. After 3 seconds, the electronic beeper makes three short beeps to tell you the Auto Restart has been selected.
- To cancel the Auto Restart, follow the steps described in the section Auto Restart Function of the Owner's Manual.

9. TROUBLESHOOTING CHART

9-1. Troubleshooting Procedure

Follow the details of **9-2. Basic Check Items**.
If there is no trouble corresponding to 9-2, check whether or not there are faulty parts following 9-4. Self-Diagnosis by Remote Control.

9-2. Basic Check Items

9-2-1. Power supply voltage

The line voltage must be AC 220 V. If it is not within this range, the air conditioner may not operate normally.

9-2-2. Incorrect cable connection between Indoor and outdoor units

The indoor unit is connected to the outdoor unit with 5 cables (Heat pump model) or 3 cables (Cooling Only model). Check that the indoor and outdoor units have been properly connected with terminals assigned the same numbers. If the connectors are not properly connected, the outdoor unit will not operate normally, or OPERATION lamp and TIMER lamp will blink (5Hz).

9-2-3. Program control

The microcontroller operates as shown in Table 9-2-1 to control the air conditioner. If there are any operational problems, check whether or not the problems correspond to Table 9-2-1. If they correspond to the Table, they are not problems with the air conditioner, but they are indispensable operations to control and maintain the air conditioner properly.

Table 9-2-1

No.	Operation of air conditioner	Descriptions
1	When the main power supply is turned on, the OPERATION lamp on the indoor unit blinks.	The OPERATION lamp blinks to indicate that power is turned on. If the [⏻] button is pressed, the lamp stops blinking.
2	The indoor fan motor speed does not change in the Dry operation.	The indoor fan motor speed is automatically controlled in the Dry operation.
3	The compressor is not turned off even though the room temperature is in the range that the compressor is turned off.	The compressor has a function that it is not turned off for 3 minutes after it is turned on even though the room temperature is in the range that the compressor is turned off.
4	The compressor is not turned on and off even though the thermo control is operated in the Dry operation.	In the Dry operation, the compressor is turned on and off automatically at the regular intervals, independent of the thermo control.
5	The compressor is not turned on even though the room temperature is in the range that the compressor is turned on.	The compressor is not turned on in the restart delay timer (3-minutes timer) operation. It is also not turned on after the power supply is turned on because of this timer operation.
6	The operation mode changes in the Automatic operation.	In Automatic operation, the room temperature is detected all time for control fan speed and the operation mode is changed every 15 minutes according to difference between the room temperature and the preset temperature.
7	The Fan only operation continues in the Automatic operation.	When the room temperature is in the range (Preset temperature $\pm 1^{\circ}\text{C}$), the Fan only operation is selected.
8	The Hi-POWER operation does not work.	This operation does not work when the unit is in the Dry operation or Fan only operation.

9-3. Primary Judgement

9-3-1. Role of indoor unit controller

The indoor unit controller receives the operation commands from the remote control and executes them.

- Temperature measurement at the air outlet of the indoor heat exchanger by the indoor temperature sensor
- Temperature setting of the indoor heat exchanger by the heat exchanger sensor
- Louver motor control
- Indoor fan motor operation control
- LED display control
- Transferring of operation commands to the outdoor unit

9-3-2. Failure diagnosis

The indoor unit diagnoses the operation condition and indicates the information of the self-diagnosis with the lamps on the display panel of the indoor unit.

Table 9-3-1

	Lamps	Self-diagnosis
A	OPERATION lamp is blinking. (1Hz)	Power failure (when the power supply is turning on)
B	OPERATION lamp is blinking. (5Hz)	Thermo sensor (TA) short or break
C	OPERATION lamp is blinking. (5Hz)	Heat exchanger sensor (TC) short or break
D	OPERATION lamp is blinking. (5Hz)	Indoor fan motor lock or failure
E	OPERATION lamp is blinking. (5Hz)	Indoor P.C. board failure
F	OPERATION and TIMER lamps are blinking. (5Hz)	Wrong wiring of connecting cable
G	OPERATION, TIMER and PRE-DEF. (or FAN ONLY for cooling only model) lamps are blinking.	Cycle failure <ul style="list-style-type: none"> • Gas shortage or other refrigerant cycle trouble • Heat exchanger sensor open, break or short • Overload relay or thermostat trouble of compressor

Table 9-3-2 Diagnosis by detective operation

Symptom	Check	Primary judgement	
The remote control does not work.	Turn off the power supply once, then turn it on. Try to operate the remote control.	The remote control still does not work.	The indoor unit (and/or remote control) is/are defective.
		The remote control works.	OK.
The outdoor fan does not rotate.	The compressor operates.	The outdoor unit (Outdoor fan motor) is defective.	
	The compressor does not operate.	An internal part of the compressor or P.C. board is defective.	

9-4. Self-Diagnosis by Remote Controller (Check Code)

1. If the lamps are indicated as shown B to E in Table 9-3-1, execute the self-diagnosis by the remote controller.
2. When the remote controller is set to the service mode, the indoor controller diagnoses the operation condition and indicates the information of the self-diagnosis on the display of the remote controller with the check codes. If a fault is detected, all lamps on the indoor unit will flash at 5Hz and it will beep for 10 seconds (Beep, Beep, Beep ...). The timer lamp usually flashes (5Hz) during self-diagnosis.

9-4-1. How to Use Remote Controller in Service Mode

1 Press [CHECK] button with a tip of pencil to set the remote controller to the service mode.

- "00" is indicated on the display of the remote controller.

2 Press [ON▲] or [OFF▲] button

If there is no fault with a code, the indoor unit will beep once (Beep) and the display of the remote controller will change as follows :

→ 00 → 01 → 02 ... 1d → 1E → 33

- The TIMER indicator of the indoor unit flashes continuously. (5 times per 1 sec.)
- Check the unit with all 52 check codes (00 to 33) as shown in Table-11-4-1.
- Press [ON▼] or [OFF ▼] button to change the check code backward.

If there is a fault, the indoor unit will beep for 10 seconds (Beep, Beep, Beep...).

Note the check code on the display of the remote controller.

- 2-digits alphanumeric will be indicated on the display.
- All indicators on the indoor unit will flash. (5 times per 1 sec.)

3 Press [CLR] button. After service finish for clear service code in memory.

- "7F" is indicated on the display of the remote control.

4 Press [⏻] button to release the service mode.

- The display of the remote controller returns to as it was before service mode was engaged.

Alphanumeric characters are used for the check codes.

5	is 5.	6	is 6.
A	is A.	b	is B.
C	is C.	d	is D.

Fig. 9-4-1

Table 9-4-1

Block level		Diagnosis function				Judgement and action
Check code	Block	Check code	Symptom	Air Conditioner status	Condition	
00	Indoor P.C. board	01	Thermo. sensor short/break.	Continued operation.	Indicated when detected abnormal	1. Check thermo sensor. 2. If it is OK, check P.C. board.
		0d	Heat exchanger sensor short/break.	Continued operation.	Indicated when detected abnormal	1. Check heat exchanger sensor. 2. If it is OK, check P.C. board.
		11	Indoor fan lock, abnormality of indoor fan or thermal fuse break.	All off	Indicated when detected abnormal	1. Check heat thermal fuse is blow or not? (Terminal block part.) 2. If the thermal fuse is not blow, check indoor fan motor. (Refer to trouble shooting flow charts.)
		12	Abnormality of other indoor unit P.C. board.	All off	Indicated when detected abnormal	Replace P.C. board.
01	Cable connection/ Thermal fuse Refrigerant system	04	1) Wrong wiring or disconnection of connective cable. 2) Terminal fuse cut off.	All off	Indicated when detected abnormal	1. Check connective cable correct if wiring is wrong. 2. Check thermal fuse and Terminal blocks. 3. If it is OK, check P.C. board.
03	Other parts (including compressor)	09	1) Overload relay or thermostat for compressor break.	All off	Indicated when detected abnormal	1. If overload relay and thermostat for compressor are OK, check refrigerant cycle. 2. If refrigerant cycle is OK, check P.C. board. 3. If heat exchanger sensor is OK, check overload relay and thermostat for compressor.
Content detected by the check codes "04" to "1d" are stored in memory of the microcomputer even if the power supply is turned off. Therefore, contents of operations in the past are all displayed.						

9-5. Troubleshooting Flowcharts

9-5-1. Power can not be turned on (No operation at all)

<Preliminary checks>

- (1) Is the supply voltage normal?
- (2) Is the connection to the AC output OK.?

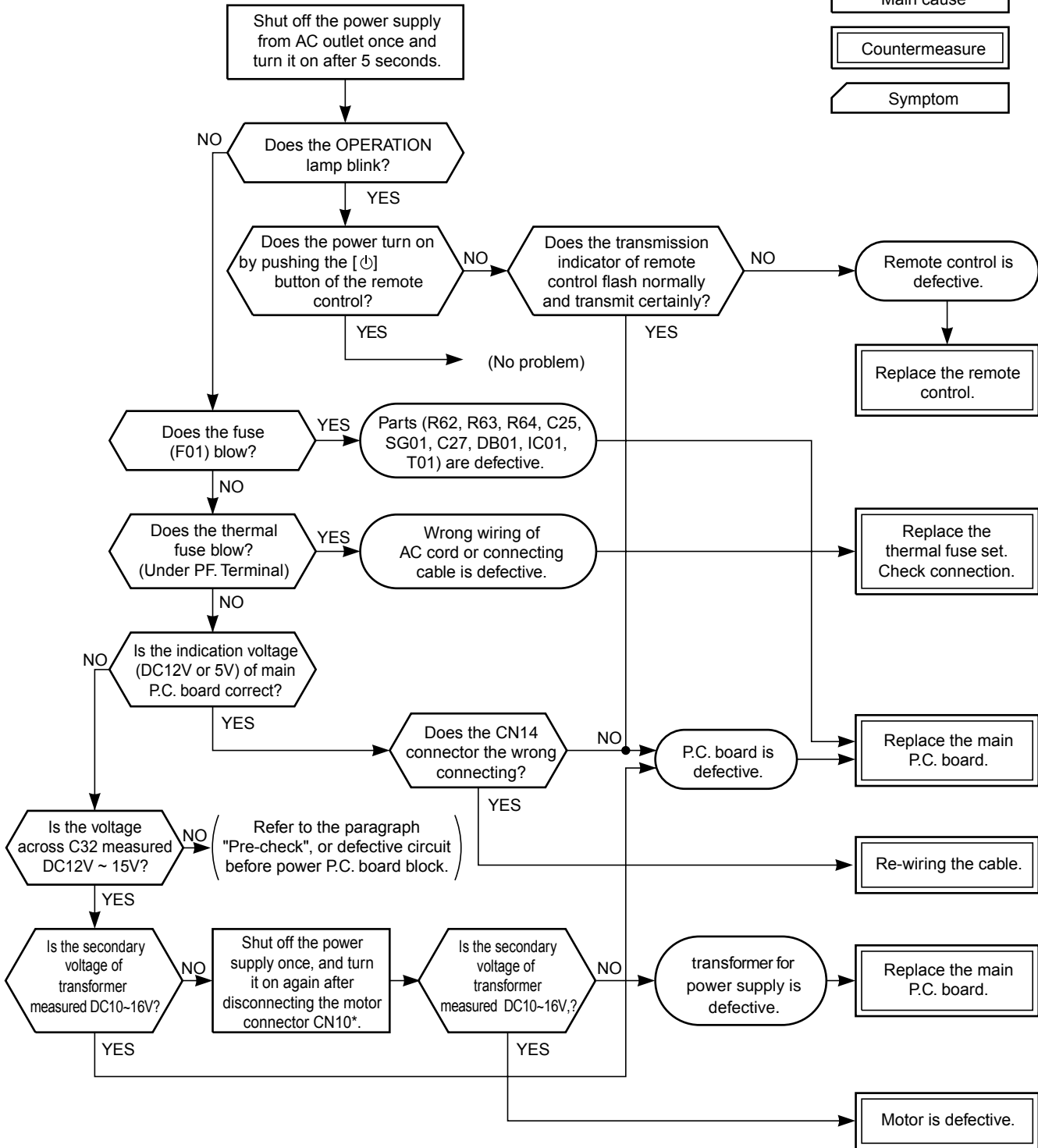
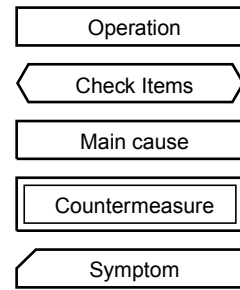

* Be sure to disconnect the motor connector CN10 after shut off the power supply, or it will be a cause of damage of the motor.

9-5-2. Power can not be turned on after replacing indoor P.C. board

<Checking Procedure>

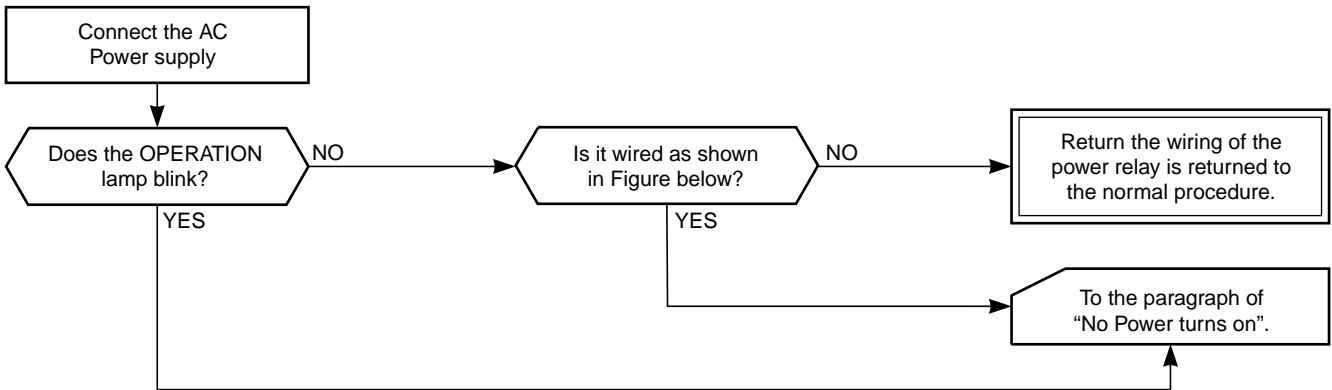

RAS-13SKPX-IN-1

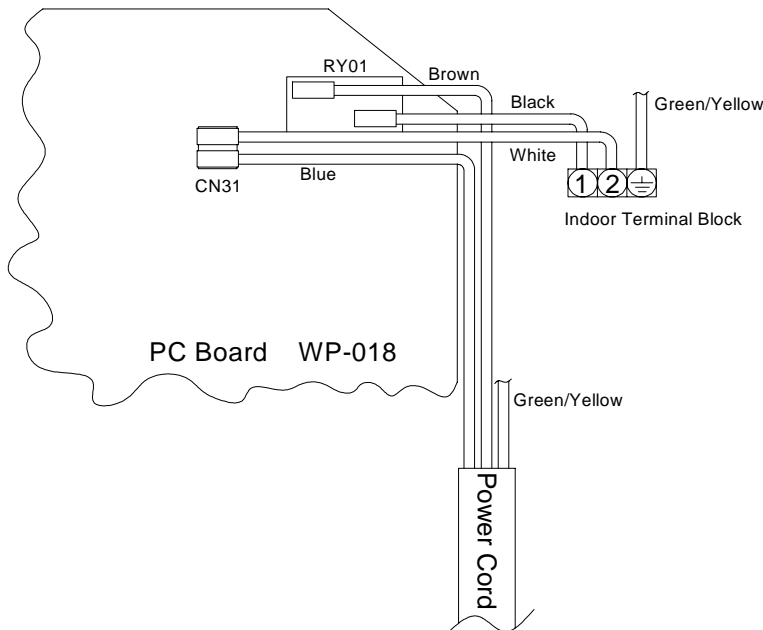

RAS-13SKP-E

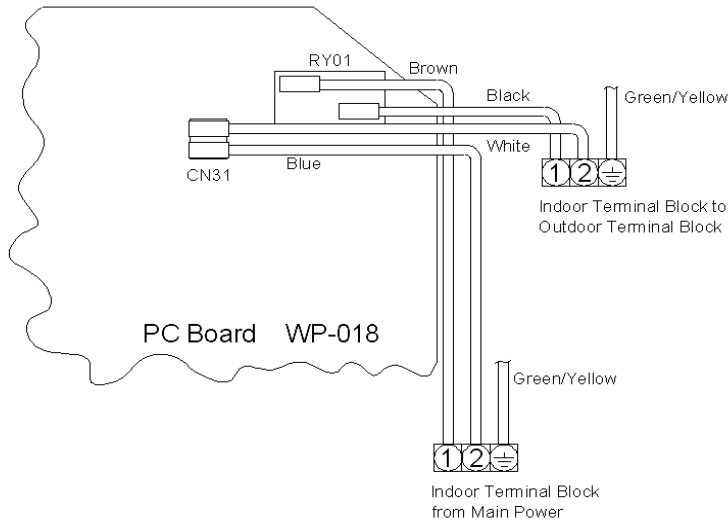

9-5-3. Outdoor unit does not operate

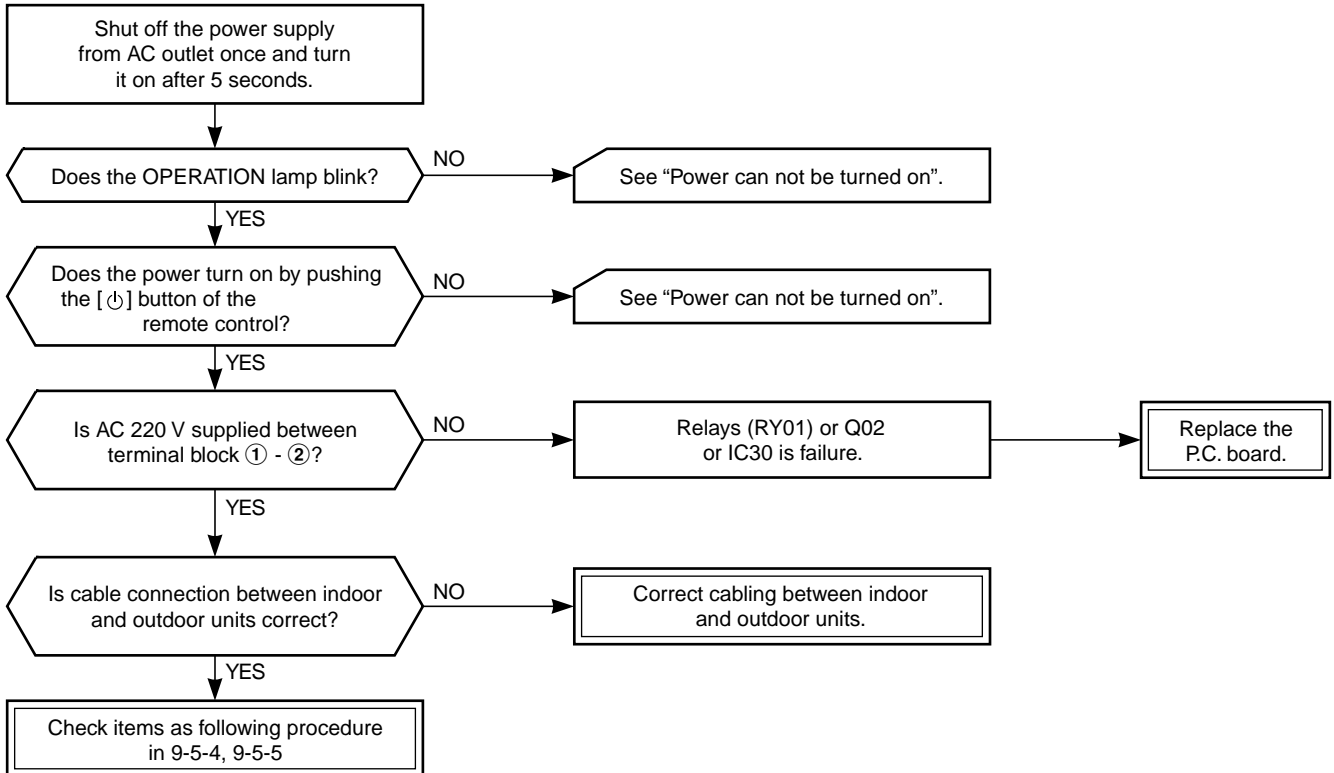

9-5-4. Only compressor does not operate

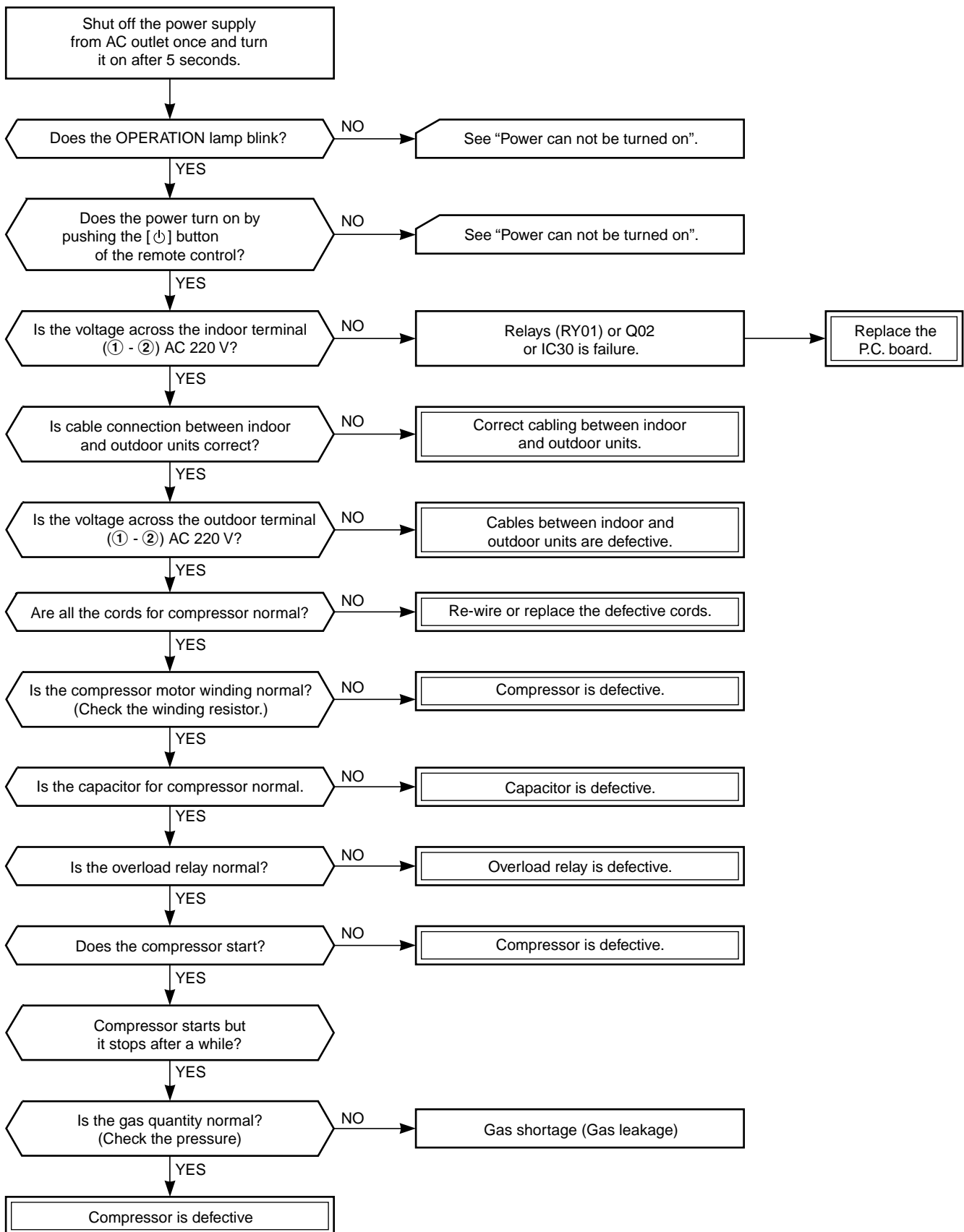

9-5-5. Only outdoor fan does not operate

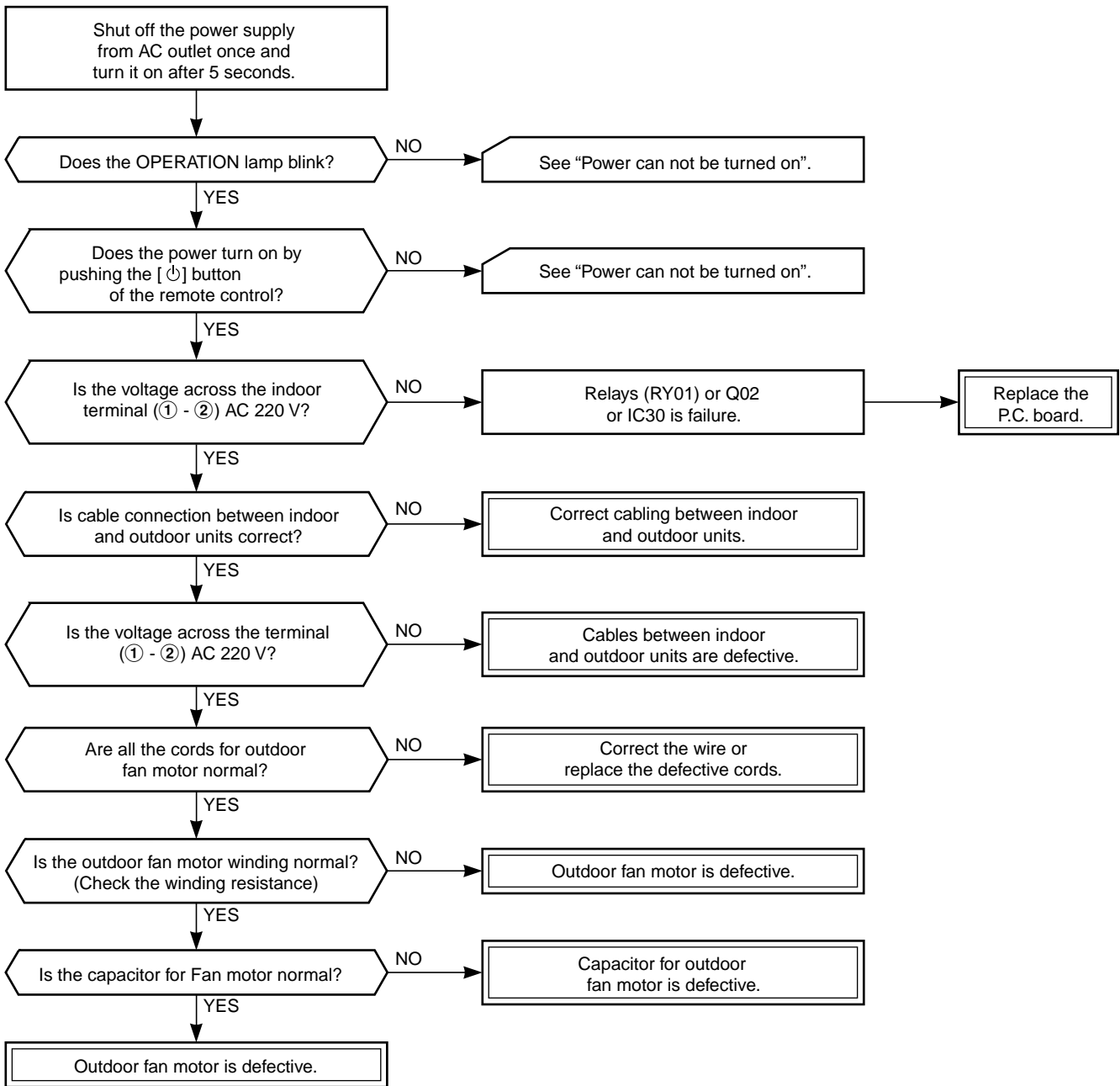

9-5-6. Only the indoor fan does not operate

<Check procedure>

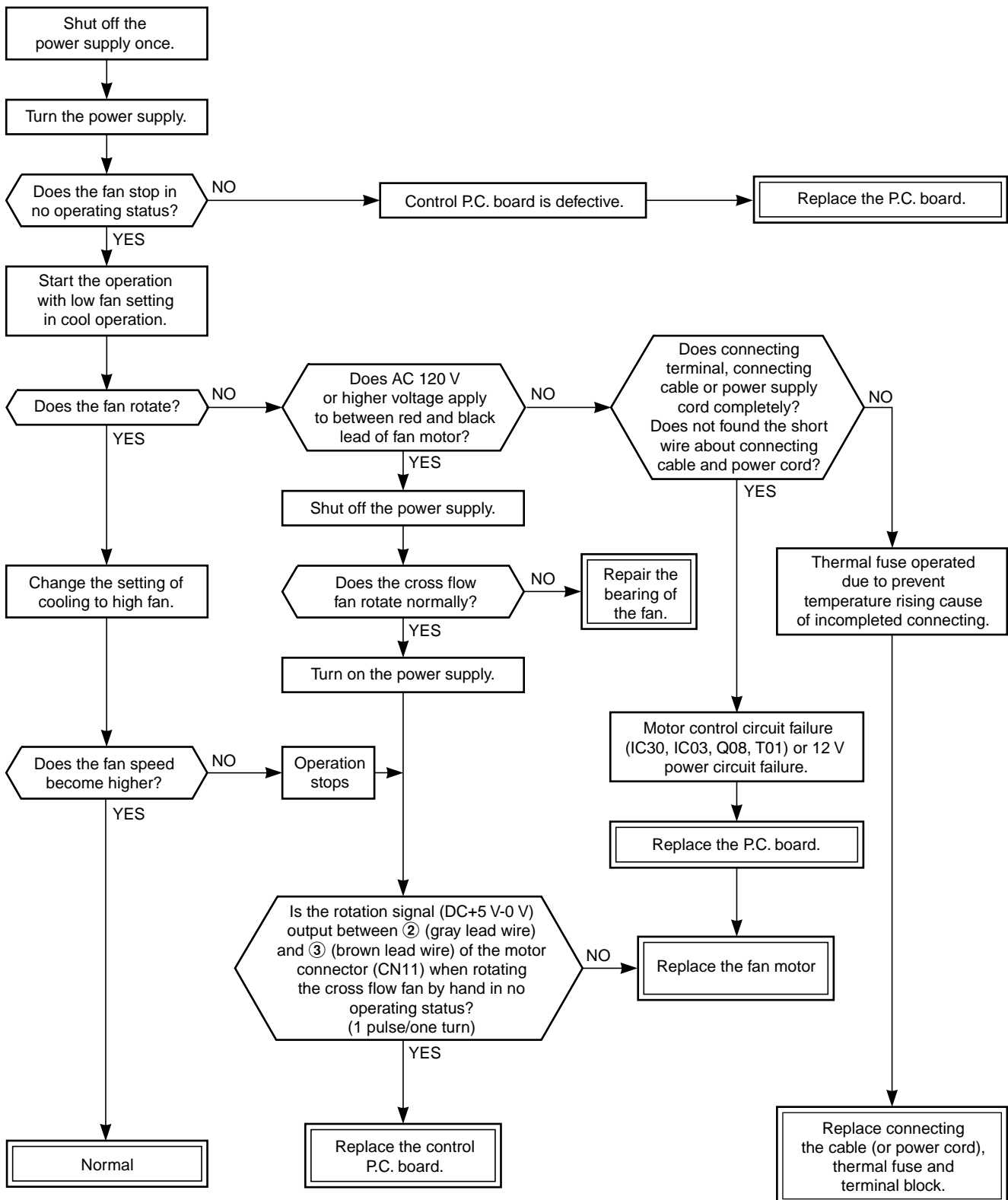

9-6. Troubleshooting for Remote Control (Including the Indoor P.C. Board)

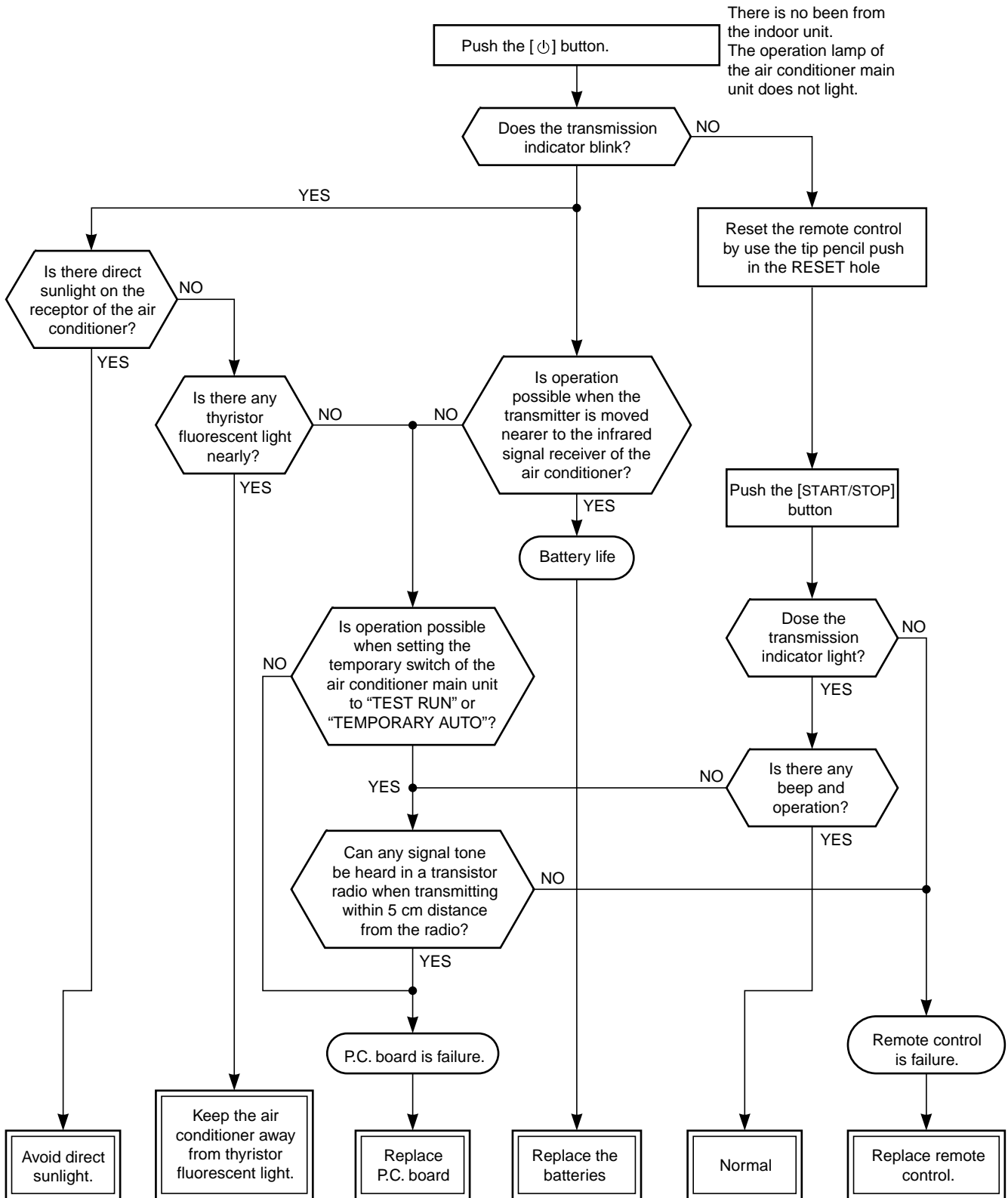

9-6-1. How to check the P.C. board

(1) Operating precautions

- 1) When removing the front panel or the P.C. board, be sure to shut off the power supply.
- 2) When removing the P.C. board, hold the edge of the P.C. board and do not apply force to the parts.
- 3) When connecting or disconnecting the connectors on the P.C. board, hold the Whole housing. Do not pull at the lead wire.

(2) Inspection procedures

- 1) When a P.C. board is judged to be defective, check for disconnection, burning, or discoloration of the copper foil pattern or this P.C. board.
- 2) The P.C. board consists of the following 2 parts
 - a. Main P.C. board part:**
power relay, indoor fan motor drive circuit and control circuit, C.P.U. and peripheral circuits, buzzer drive circuit and buzzer.
 - b. Infrared rays receive and indication parts:**
Infrared rays receiver unit and LED.

(3) Checking procedure

Table 9-6-1

No.	Procedure	Check Point (Symptom)	Causes
1	Shut off the power supply and remove the P.C. board assembly from the electronic parts base. Remove the connecting cable from the terminal block.	1. Is the fuse blown?	1. • Application of shock voltage. • Overload by short-circuit of the parts.
2	Remove the connector for the motor, and turn the power on. If the OPERATION lamp blinks (0.5 sec. : ON, 0.5 sec. : OFF) when the power turning on, the checking points described as 1-4 of right column are not necessary to perform.	Voltage check 1. Between 3 of RY01 and CN31 (AC 220~240V) 2. Between + and - of C27 (DC 310 ~ 390V) 3. Between 12V and GND 4. Between 5V and GND	1. • AC power cord is defective. • Poor contact of the terminal plate. • Miss wiring of the power relay. 2. • Capacitor (C25, C26, C27) is defective. • Line filter (L01) is defective. • Diode (DB01) is defective. 3. T01 are defective. 4. IC02 are defective.
3	Make the operation status by pushing once the [ϕ] button, except the status of [FAN ONLY], [ON TIMER].	Voltage check 1. Voltage of relay coil. (DC 12V) Between pin 2 of RY01 and GND 2. Between No. 1 and 2 of connecting cable terminal block. (AC 220~240V)	1. Breaking wire of the relay coil, defective relay driver. (Q02) 2. Poor contact of relay.
4	Start the operation with the system which the time of the restart delay timer is shortened.	1. All indicators light for 3 sec.. 2. Indicators do not indicate normally after approximate 3 sec..	} Defective indicator, or poor housing assembly. (CN14)
5	Make the operation status by pressing once the [ϕ] button. 1. The time of the restart delay timer is shortened. 2. Cool operation 3. Air volume [AUTO] 4. Make the setting temperature lower enough than room temperature. 5. Continuous operation.	1. Compressor does not operate. 2. OPERATION lamp blinks.	1. The temperature of the indoor heat exchanger is abnormally lower. 2. Poor contact of the heat exchanger sensor. (The connector is disconnected.) (CN01) 3. Heat exchanger sensor, main P.C. board are defective. (Refer to Table 9-6-2 for the judgment of defective resistance values.) 4. Main P.C. board is defective.
6	Turn the power on after connecting the motor connector. Start the operation with the following condition. 1. Operation [Cooling] 2. Airflow [High fan] 3. Continuous operation	1. Motor does not rotate. (The key operation is accepted.) 2. The Motor rotates, but it vibrates too much.	1. Poor contact of the motor connector. 2. P.C. board is defective.

Table 9-6-2 Approximate resistance value of thermo sensor

Temperature	0°C	10°C	20°C	25°C	30°C
Resistance value	33.8	20.35	12.59	10.00	7.99

(kΩ)

9-6-2. How to shorten time of restart delay timer

- ① Press [SET] button while pressing [CHK] button with a tip of a pencil.
- ② Then press [⏻] button to transmit the signal to the indoor unit.

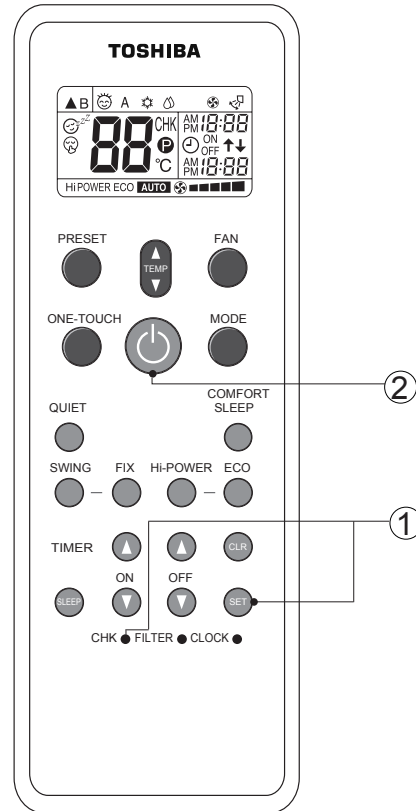

9-6-3. How to set/cancel the self cleaning function

The self cleaning function is set from a factory. To cancel this function, should keep press the [RESET] button for 20 seconds till can hear the long combination sound and repeat the same procedure when need to set.

10. HOW TO REPLACE THE MAIN PARTS

WARNING

- Since high voltages pass through the electrical parts, turn off the power without fail before proceeding with the repairs.
Electric shocks may occur if the power plug is not disconnected.
- After the repairs have been completed (after the front panel and cabinet have been installed), perform a test run, and check for smoking, unusual sounds and other abnormalities.
If this check is omitted, a fire and/or electric shocks may occur.
Before proceeding with the test run, install the front panel and cabinet.
- Ensure that the following steps are taken when doing repairs on the refrigerating cycle.
 1. Do not allow any naked flames in the surrounding area.
If a gas stove or other appliance is being used, extinguish the flames before proceeding.
If the flames are not extinguished, they may ignite any oil mixed with the refrigerant gas.
 2. Do not use welding equipment in an airtight room.
Carbon monoxide poisoning may result if the room is not properly ventilated.
 3. Do not bring welding equipment near flammable objects.
Flames from the equipment may cause the flammable objects to catch fire.
- **If keeping the power on is absolutely unavoidable while doing a job such as inspecting the circuitry, wear rubber gloves to avoid contact with the live parts.**
Electric shocks may be received if the live parts are touched.
High-voltage circuits are contained inside this unit.
Proceed very carefully when conducting checks since directly touching the parts on the control circuit board may result in electric shocks.

10-1. Indoor Unit

No.	Part name	Procedures	Remarks
①	Front panel	1) Stop operation of the air conditioner and turn off its main power supply. 2) Open the air inlet grille, push the arm toward the outside, and remove the grille. 3) Remove the left and right air filters.	

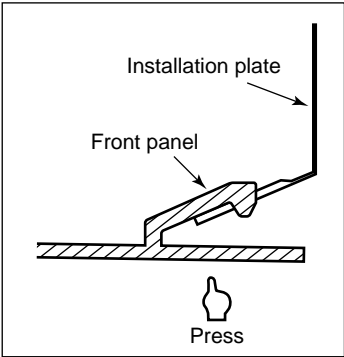
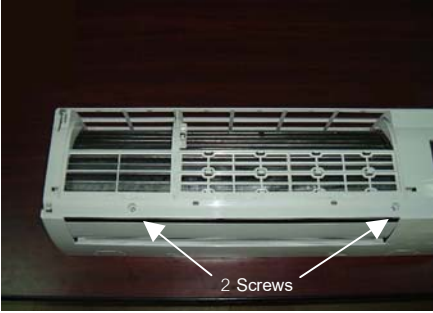
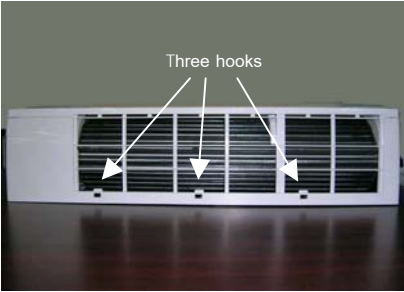
No.	Part name	Procedures	Remarks
①	Front panel	<p>4) Press "PUSH" part under the front panel and remove hooks of the front panel from the installation plate.</p> <p>5) Remove the front panel fixing screws. (2 pcs.)</p> <p>6) Take off three hooks of panel from rear side.</p> 	  
		<p><How to assemble the front panel></p> <p>1) Press three center positions and two lower center positions of the air outlet, and then hang the hanging hooks (3 pcs.) at the top side of the front panel to the rear plate.</p> <p>2) Tighten two screws.</p> <ul style="list-style-type: none"> • Incomplete hanging or incomplete pressing may cause a dewdrops or generation of a fluttering sound. 	

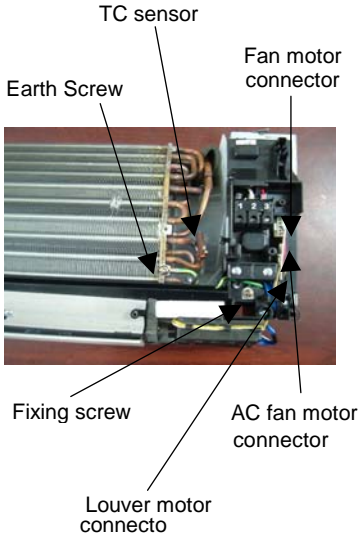

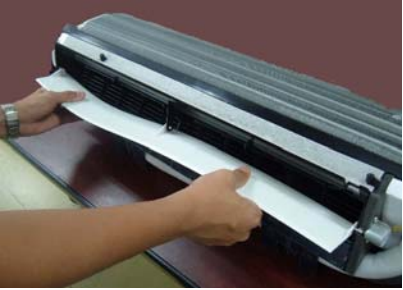
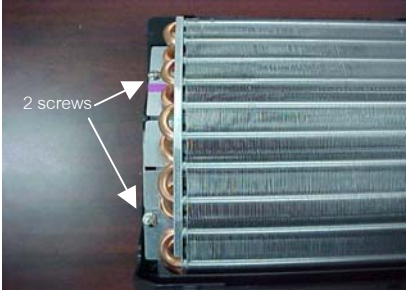
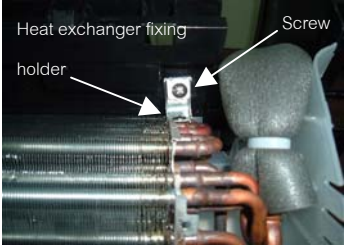
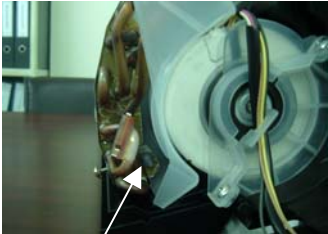
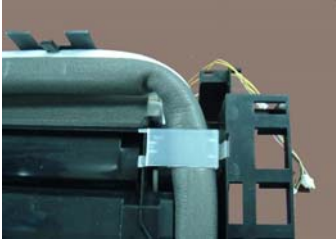
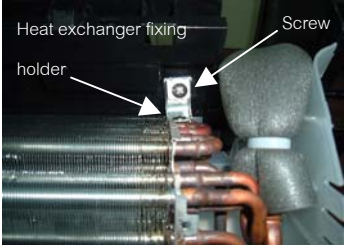
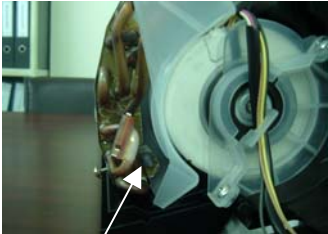

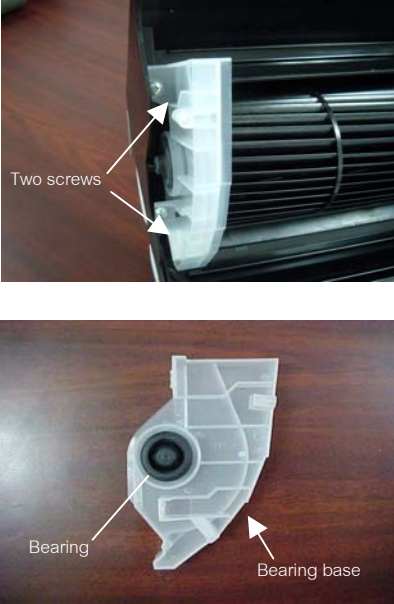
No.	Part name	Procedures	Remarks
②	Electric parts box assembly	<p>1) Follow the procedure ①</p> <p>2) Remove screw of earth lead attached to the end plate of the evaporator.</p> <p>3) Remove the lead wire cover, and remove connector for the fan motor and connector for the louver motor from the electric parts box assembly.</p> <p>4) Pull out TC sensor from sensor holder of the evaporator.</p> <p>5) Disengage the display unit by simply pushing at the top of the display unit.</p> <p>6) Remove the fixing screw that secures the electric parts box assembly, and remove the assembly.</p> <p><How to assemble the electric parts box></p> <p>1) Hook the top part of the electric parts box assembly onto the claws on the back body, and secure it using the fixing screw. Now attach the display unit. Connect the connectors for the fan motor and louver motor.</p> <p>2) Secure the grounding wire using the fixing screw. Insert the TC sensor into the sensor holder.</p> <p>* Be absolutely sure to loop the grounding wire and TC sensor leads once at the bottom.</p>	 <p>Electric part box cover</p>  <p>TC sensor</p> <p>Earth Screw</p> <p>Fan motor connector</p> <p>Fixing screw</p> <p>AC fan motor connector</p> <p>Louver motor connecto</p>

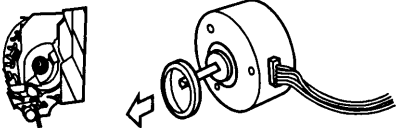
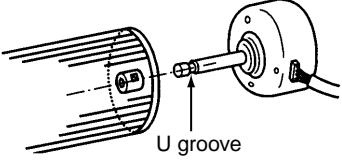
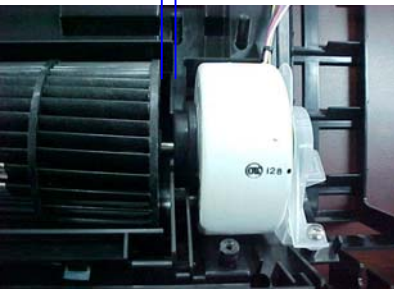
No.		Procedures	Remarks
③	Horizontal louver	1) Remove shaft of the horizontal louver from the back body. (First remove the left shaft, and then remove other shafts while sliding the horizontal louver leftward.)	
④	Evaporator (Heat exchanger)	1) Follow to the procedure in the item ②. 2) Remove the pipe holder from the rear side of the main unit. 3) Remove two fixing screws at the left side of the end plate of the heat exchanger.  4) Remove one fixing screw on the heat exchange fixing holder to separate the heat exchange from the back body.  5) Remove right side of the end plate from two fixing rib while sliding slightly the heat exchanger rightward. 	  

No.	Part name	Procedures	Remarks
⑤	Bearing	<p>1) Follow to the procedure in the item ④.</p> <p>2) Remove the two screws used to secure the bearing base.</p> <p>3) Remove the bearing base.</p> <p><Caution at assembling></p> <ul style="list-style-type: none">• If the bearing is out from the housing, push it into the specified position and then incorporate it in the main body.	 <p>The top photograph shows a close-up of a white plastic bearing base being attached to a metal housing. Two screws are visible, securing the base. A label 'Two screws' with arrows points to the screws. The bottom photograph shows the bearing base removed from the housing. The bearing is visible inside the base. Labels 'Bearing' and 'Bearing base' with arrows point to the respective parts.</p>

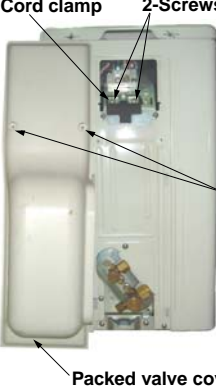
No.	Part name	Procedures	Remarks
⑦	Cross flow fan	<p><Caution at reassembling></p> <p>1) To incorporate the fan motor, remove the fan motor rubber (at shaft core side), incorporate the motor into the position in the following figure, and then install the fan motor.</p> <ul style="list-style-type: none"> • Install the cross flow fan so that the right end of the 1st joint from the right of the cross flow fan is set keeping 70.5 mm from wall of rear plate of the main unit. • Holding the set screw, install the cross flow fan so that U-groove of the fan motor comes to the mounting hole of the set screw.  <ul style="list-style-type: none"> • Perform positioning of the fan motor as follows: • When assembling the fan motor, the fan motor must be installed in such a way that the fan motor leads will be taken out is positioned at the bottom front. • After assembling the two hooking claws of the motor band (right) into the main body, position the fan motor, insert it, and then secure the motor band (right) using the two fixing screws. 	

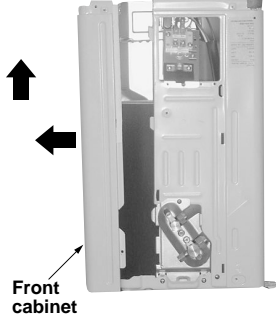
10-2. Outdoor Unit

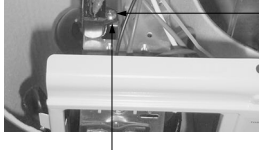
No.	Part name	Procedures	Remarks
①	Common procedure	<ol style="list-style-type: none"> 1) Stop the operation of air-conditioner, and disconnect the power cord from the AC supply. 2) Remove packed valve cover and Electric parts cover. (2-Screws $\varnothing 4 \times 10L$) 3) Remove the cord clamp (2-Screws $\varnothing 4 \times 16L$) and disconnect the connecting cable. 4) Remove the upper cabinet (5-Screws $\varnothing 4 \times 10L$) Pulling out upward. 5) Remove the front cabinet. (3-Screws $\varnothing 4 \times 10L$) Pull the front right portion toward you, and remove it pulling out upward. 	  
②	Capacitor for compressor	<ol style="list-style-type: none"> 1) Perform the common procedure ①. 2) Remove the fixing screw and the capacitor band. (1-Screw $\varnothing 4 \times 10L$) 3) Disconnect the lead wires. 	
③	Capacitor for fan motor	<ol style="list-style-type: none"> 1) Perform the common procedure ①. 2) Remove the fixing screw and the capacitor band. (1-Screw $\varnothing 4 \times 10L$) 3) Disconnect the lead wires. 	

11. EXPLODED VIEWS AND PARTS LIST

11-1. Indoor Unit (E-Parts Assy) RAS-13SKPX-IN-1

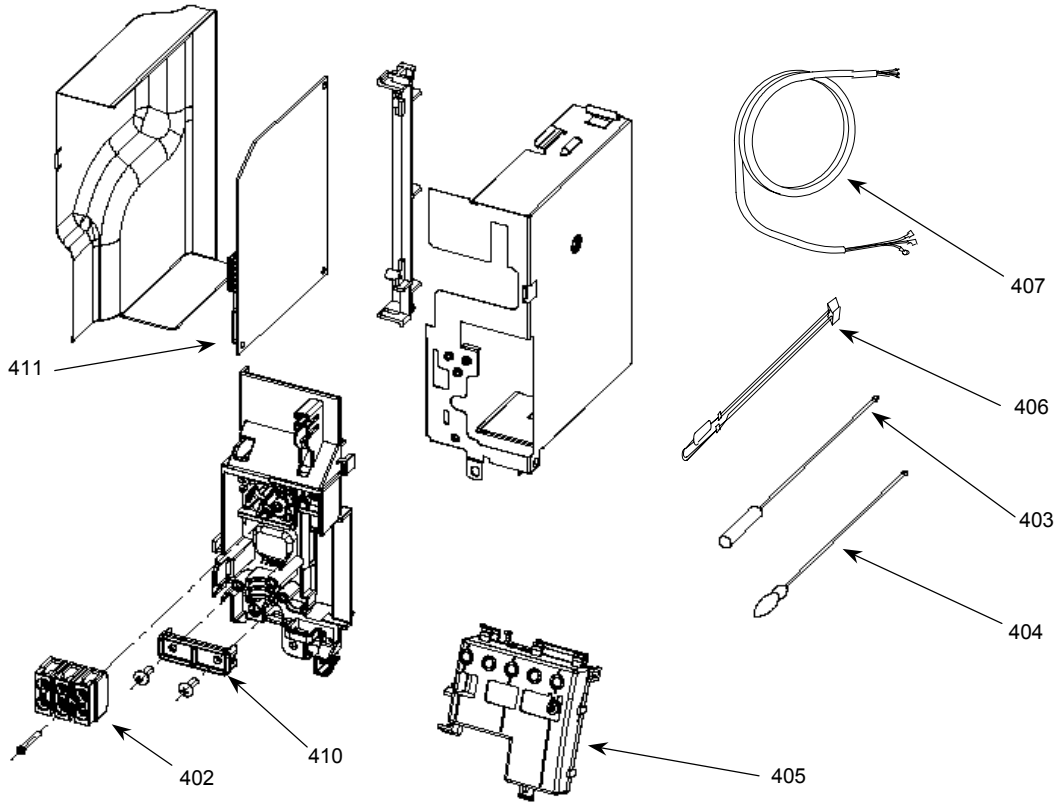

Location No.	Part No.	Description
402	43T60383	TERMINAL
403	43T69004	SENSOR;HEAT EXCHANGER
404	43T69005	SENSOR;THERMOSTAT
405	43T69641	ASM-UNIT-LED-AC

Location No.	Part No.	Description
406	43T69364	FUSE,TEMPERATURE
407	43T60366	POWER CORD
410	43T62003	CORD CLAMP
411	43T69712	ASM-PCB-SERV

11-2. Indoor Unit (E-Parts Assy) RAS-13SKP-E

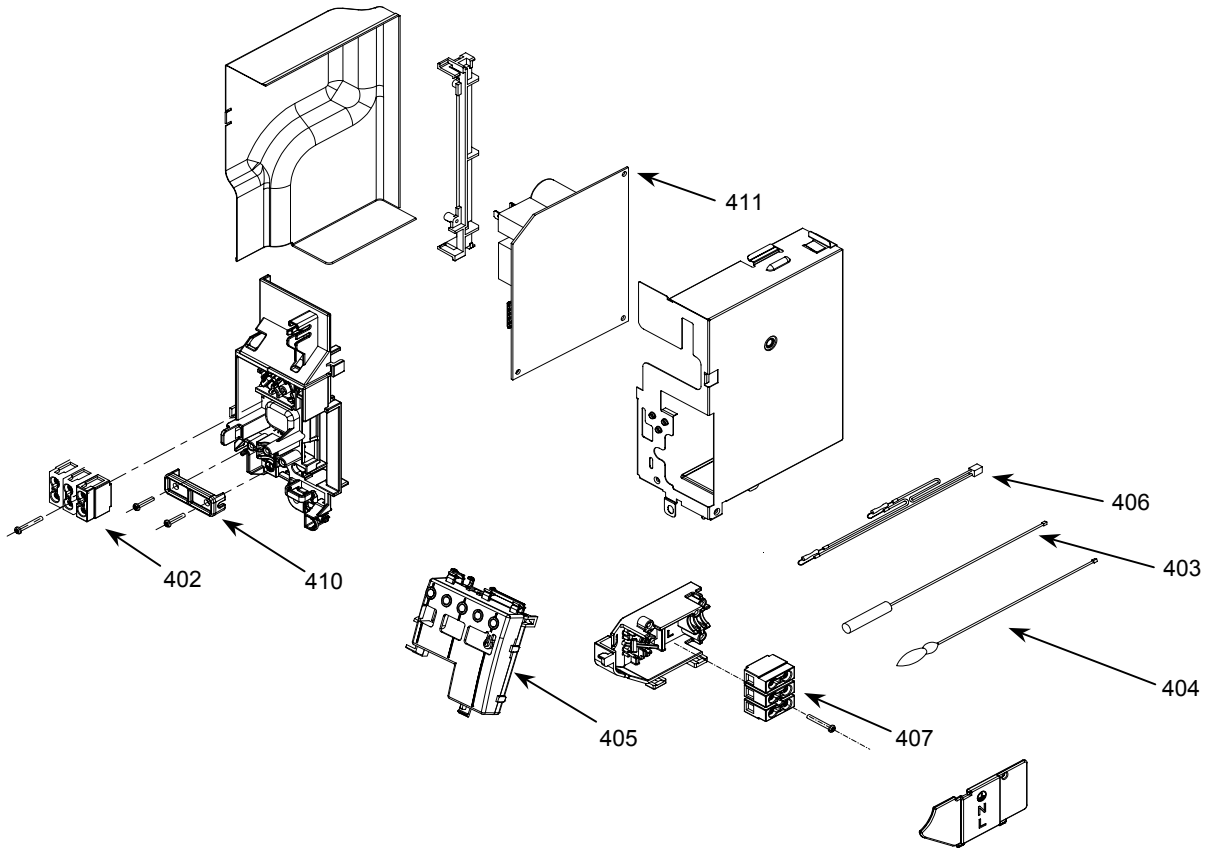

Location No.	Part No.	Description
402	43T60383	TERMINAL
403	43T69004	SENSOR;HEAT EXCHANGER
404	43T69005	SENSOR;THERMOSTAT
405	43T69641	ASM-UNIT-LED-AC

Location No.	Part No.	Description
406	43T60077	FUSE, TEMPERATURE, 73C
407	43T60002	TERMINAL BLOCK; 3P
410	43T62003	CORD CLAMP
411	43T69712	ASM-PCB-SERV

11-3. Indoor Unit (RAS-13SKPX-IN-1)

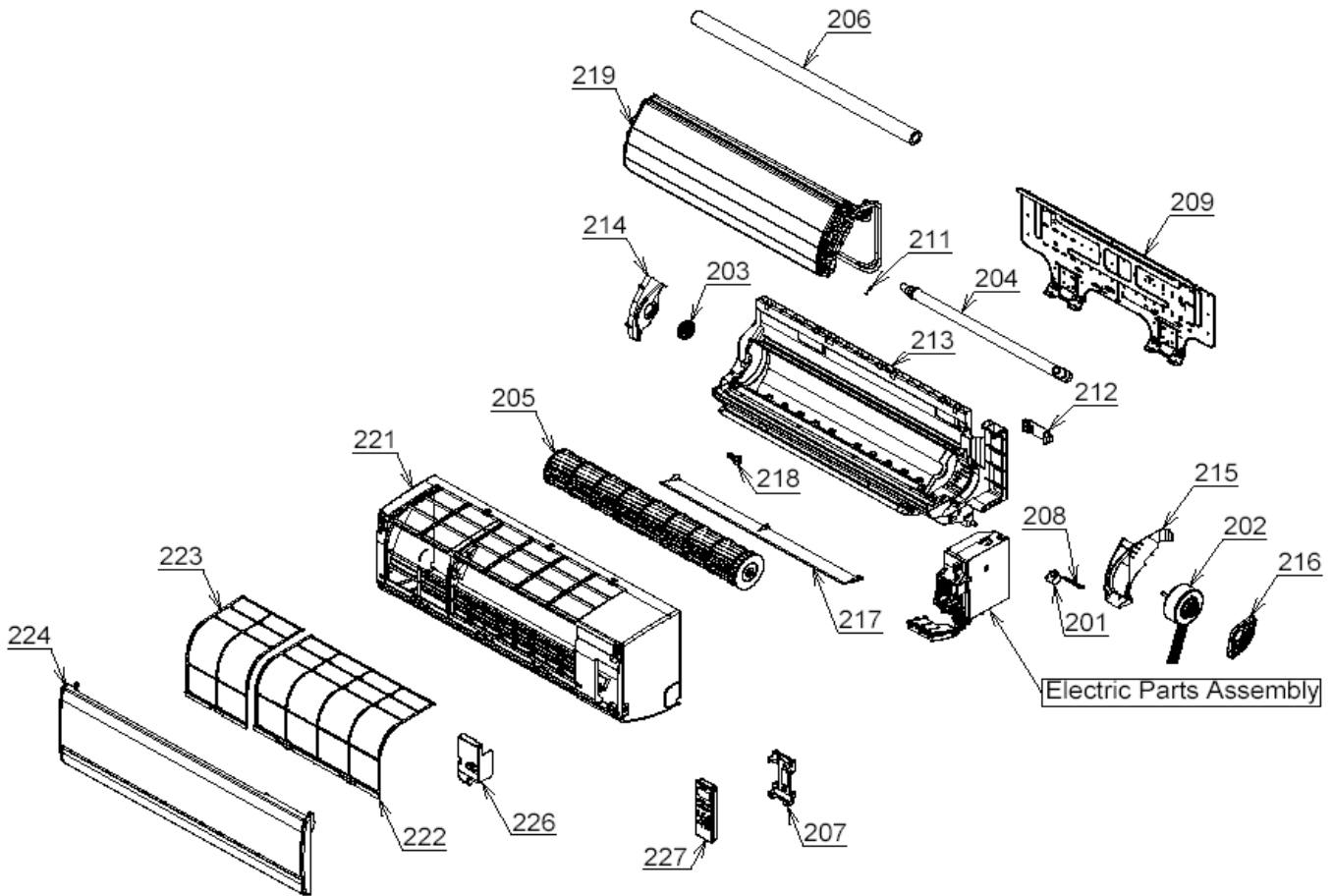

Location No.	Part No.	Description
201	43T21397	LOUVER MOTOR
202	43T21393	FAN MOTOR
203	43T22312	MOLD BEARING ASSEMBLY
204	43T70313	DRAIN HOSE
205	43T20325	CROSS FLOW FAN ASSEMBLY
206	43T49010	PIPE SHIELD
207	43T83003	REMOTE CONTROL HOLDER
208	43T60382	MOTOR CORD
209	43T82310	INSTALLATION PLATE
211	43T19333	SENSOR FIX PLATE
212	43T09408	PIPE HOLDER
213	43T03362	BACK BODY ASSEMBLY

Location No.	Part No.	Description
214	43T39327	BEARING BASE
215	43T39328	MOTOR BAND (LEFT)
216	43T39329	MOTOR BAND (RIGHT)
217	43T09409	HORIZONTAL LOUVER
218	43T79313	DRAIN CAP
219	43T44416	REFRIGERATION CYCLE ASSEMBLY
221	43T00495	PANEL SERVICE ASSEMBLY
222	43T80318	AIR FILTER (R)
223	43T80319	AIR FILTER (L)
224	43T09416	GRILLE OF AIR INLET
226	43T62328	TERMINAL COVER
227	43T69616	WIRELESS REMOTE CONTROL

11-4. Indoor Unit (RAS-13SKP-E)

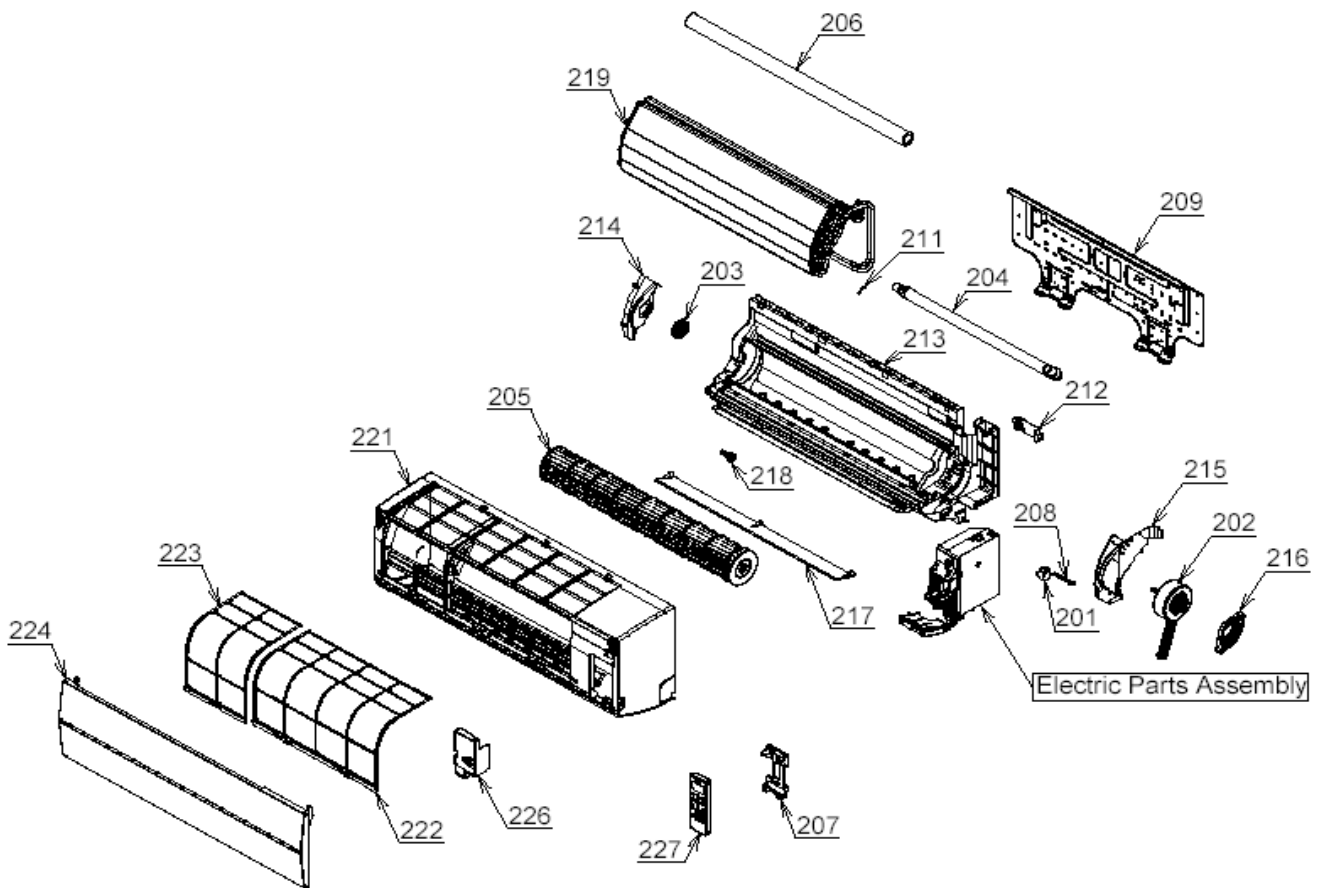

Location No.	Part No.	Description
201	43T21397	LOUVER MOTOR
202	43T21393	FAN MOTOR
203	43T22312	MOLD BEARING ASSEMBLY
204	43T70313	DRAIN HOSE
205	43T20325	CROSS FLOW FAN ASSEMBLY
206	43T49010	PIPE SHIELD
207	43T83003	REMOTE CONTROL HOLDER
208	43T60382	MOTOR CORD
209	43T82310	INSTALLATION PLATE
211	43T19333	SENSOR FIX PLATE
212	43T09408	PIPE HOLDER
213	43T03362	BACK BODY ASSEMBLY
214	43T39327	BEARING BASE

Location No.	Part No.	Description
215	43T39328	MOTOR BAND (LEFT)
216	43T39329	MOTOR BAND (RIGHT)
217	43T09409	HORIZONTAL LOUVER
218	43T79313	DRAIN CAP
219	43T44426	REFRIGERANT CYCLE ASSEMBLY
221	43T00495	PANEL SERVICE ASSEMBLY
222	43T80318	AIR FILTER (R)
223	43T80319	AIR FILTER (L)
224	43T09418	GRILLE OF AIR INLET (OPTIONAL,WHITE)
226	43T62328	TERMINAL COVER
227	43T69616	WIRELESS REMOTE CONTROL

11-5. Outdoor Unit (RAS-13SAPX-IN-1)

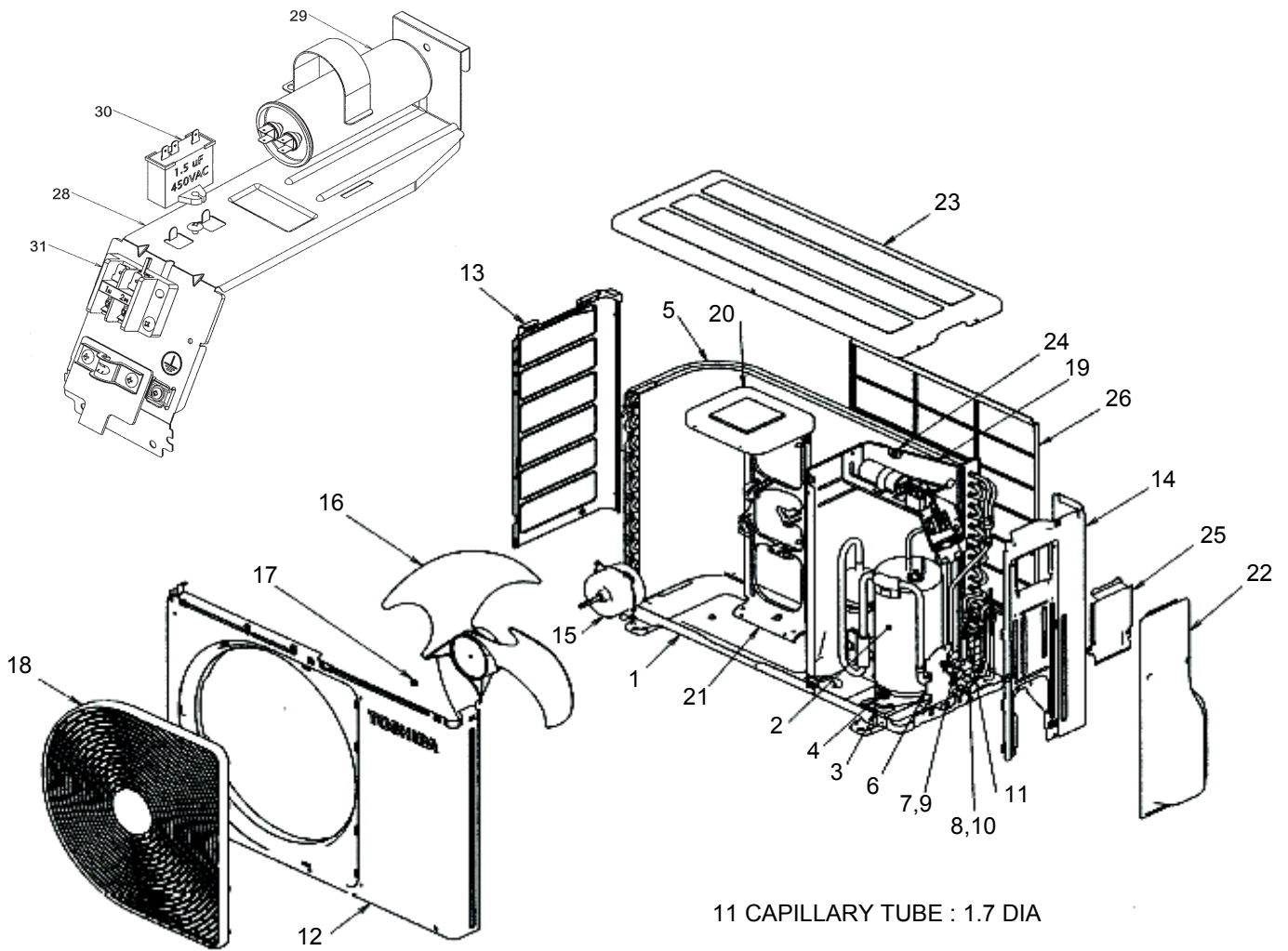

Location No.	Part No.	Description
1	43T42334	BASE PLATE ASSEMBLY
2	43T41348	COMPRESSOR(Made in China)
3	43T49008	CUSHION,RUBBER
4	43T97001	NUT
5	43T43408	CONDENSER ASSEMBLY
6	43T00448	FIXING PLATE VALVE
7	43T46332	VALVE;PACKED 6.35 DIA
8	43T46019	VALVE,PACKED 12.7 DIA
9	43T47331	BONNET, 6.35 DIA
10	43T47333	BONNET, 12.70 DIA
11	43T47014	CAPILLARY TUBE; 1.7DIA
12	43T00468	FRONT CABINET
13	43T00459	LEFT CABINET
14	43T00451	RIGHT CABINET ASSEMBLY
15	43T21362	FAN MOTOR(Made in China)

Location No.	Part No.	Description
16	43T20319	PROPELLER FAN
17	43T47001	NUT FLANGE
18	43T19329	FAN GUARD
19	43T04301	PARTITION
20	43T39317	MOTOR BASE CONNECTION PLATE
21	43T39318	MOTOR BASE
22	43T19330	PACKED VALVE COVER
23	43T00460	UPPER CABINET ASSEMBLY
24	43T96305	BUSHING
25	43T62325	ELECTRIC PART COVER
26	43T19331	FIN GUARD
28	43T61308	ELECTRIC PARTS BASE
29	43T55337	MF CAPACITOR
30	43T55325	CAPACITOR; PLASTIC-FILM
31	43T60367	TERMINAL-2P

11-6. Outdoor Unit (RAS-13S2A-E)

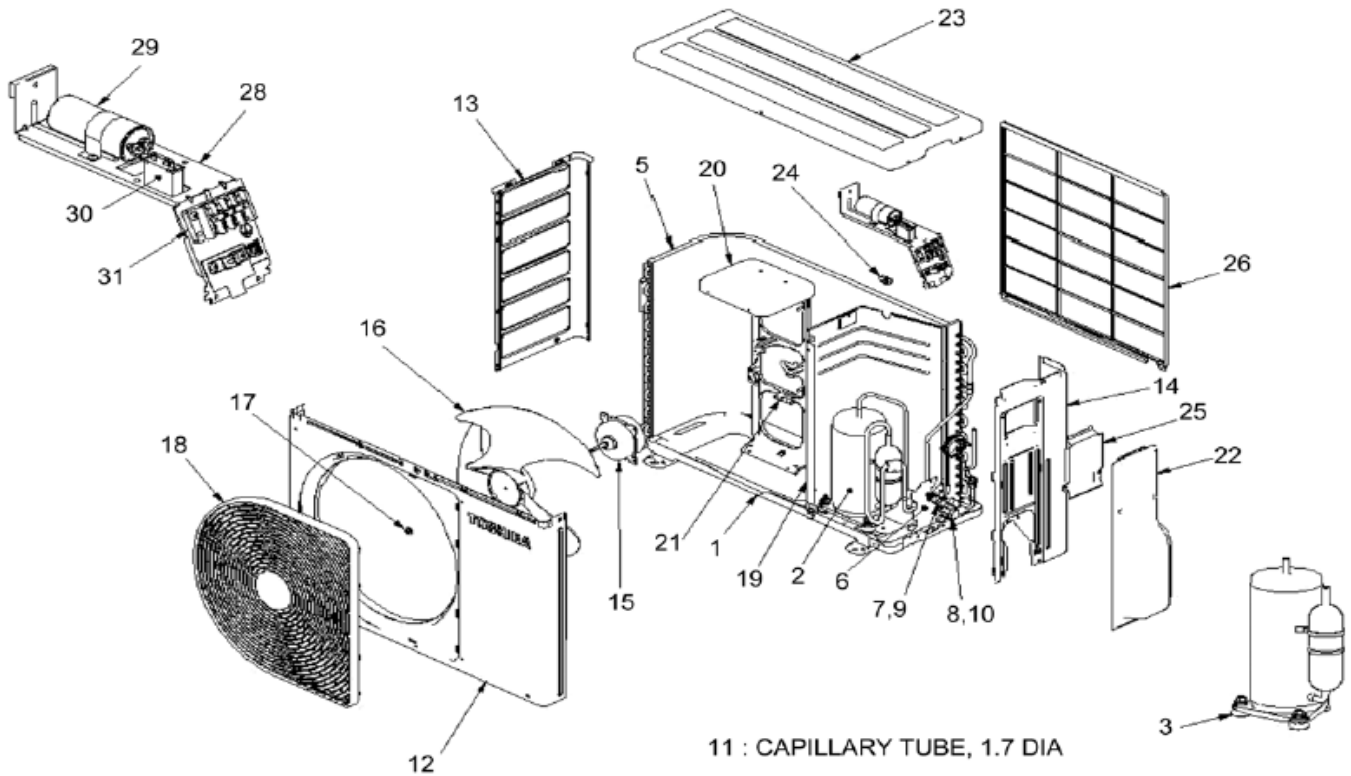

Location No.	Part No.	Description
1	43T42332	BASE PLATE ASSEMBLY
2	43T41348	COMPRESSOR(Made in China)
3	43T49008	CUSHION,RUBBER
5	43T43376	CONDENSER ASSEMBLY
6	43T00448	FIXING PLATE VALVE
7	43T46332	VALVE;PACKED 6.35 DIA
8	43T46346	VALVE;PACKED 12.7 DIA
9	43T47331	BONNET, 6.35 DIA
10	43T47333	BONNET, 12.70 DIA
11	43T47014	CAPILLARY TUBE; 1.7DIA
12	43T00468	FRONT CABINET
13	43T00459	LEFT CABINET
14	43T00451	RIGHT CABINET ASSEMBLY
15	43T21361	FAN-MOTOR
16	43T20319	PROPELLER FAN

Location No.	Part No.	Description
17	43T47001	NUT FLANGE
18	43T19329	FAN GUARD
19	43T04301	PARTITION
20	43T39322	MOTOR BASE CONNECTION PLATE
21	43T39318	MOTOR BASE
22	43T19330	PACKED VALVE COVER
23	43T00460	UPPER CABINET ASSEMBLY
24	43T96305	BUSHING
25	43T62325	ELECTRIC PART COVER
26	43T19331	FIN GUARD
28	43T61308	ELECTRIC PARTS BASE
29	43T55337	MF CAPACITOR
30	43T55325	CAPACITOR; PLASTIC-FILM
31	43T60367	TERMINAL-2P

TOSHIBA CARRIER (THAILAND) CO., LTD.

144/9 MOO 5, BANGKADI INDUSTRIAL PARK, TIVANON ROAD, TAMBOL BANGKADI,
AMPHUR MUANG, PATHUMTHANI 12000, THAILAND.